

Bind together. Send secure.

In, on & around the pallet.

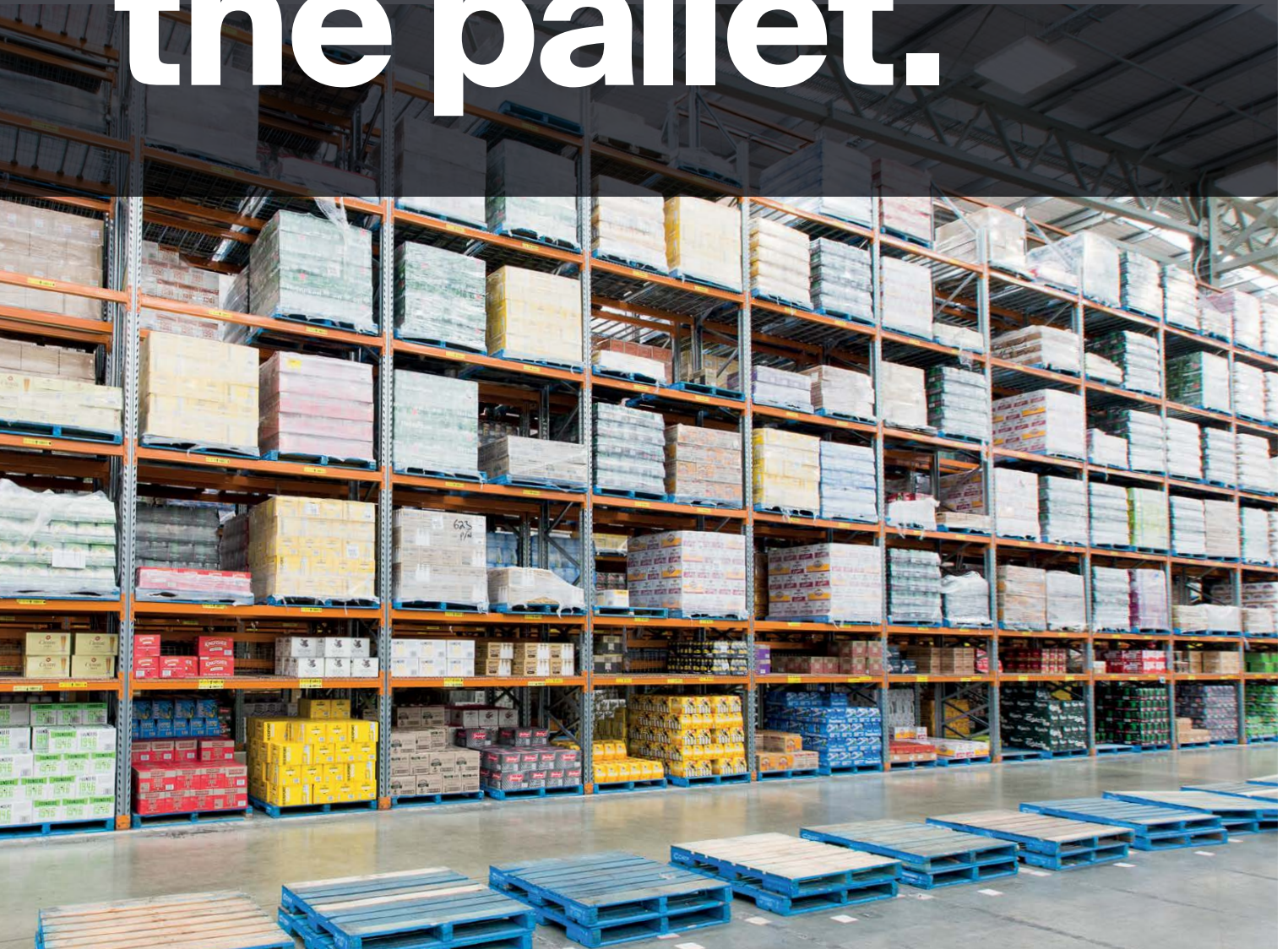

universalpackaging.co.nz

Universal 
Packaging Since 1985
A DIVISION OF Spicers 

In, on & around the pallet.

With the combined product range of Universal Packaging and Spicers NZ, our industrial packaging solutions will ensure your goods get from A to B safely, securely and, where necessary, stylishly.

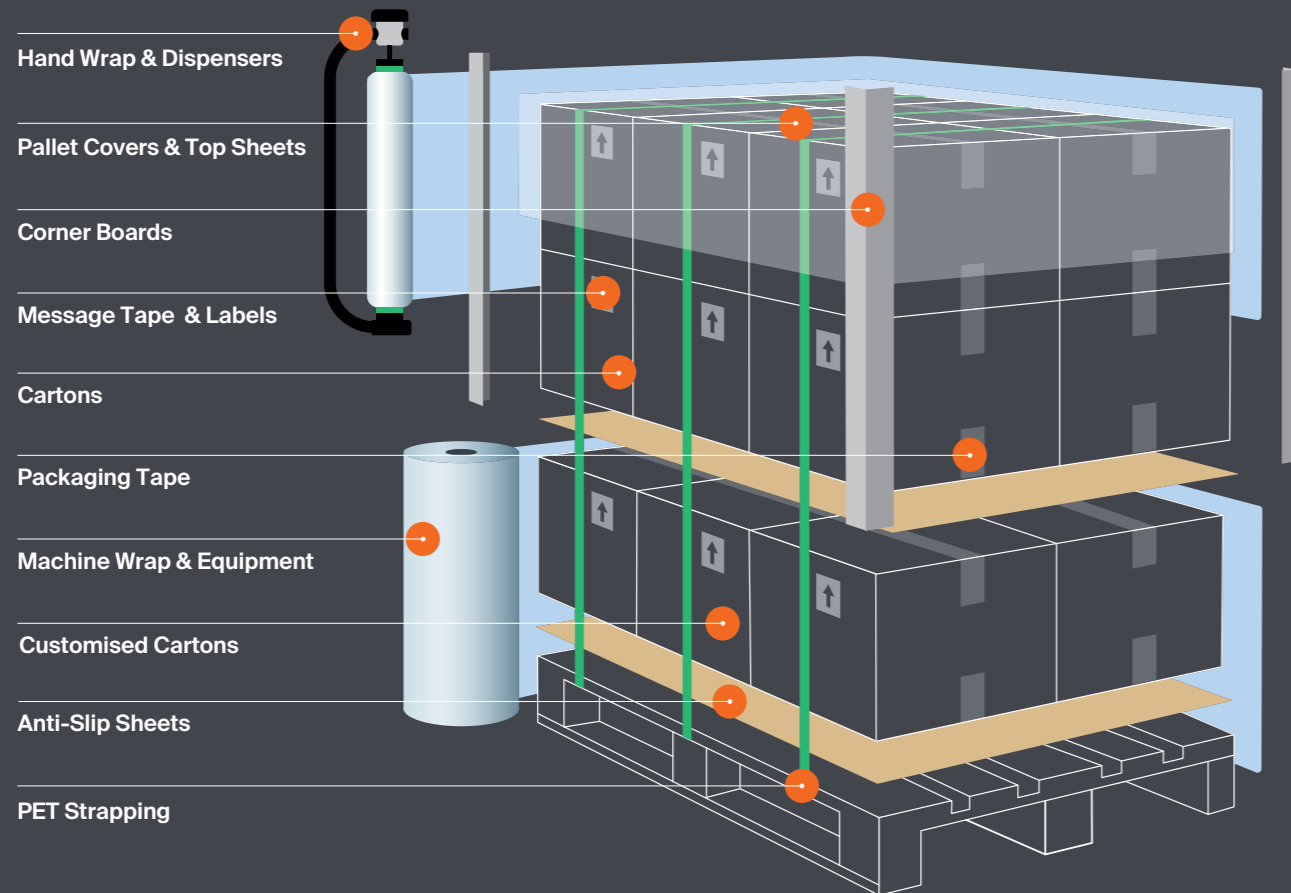

We are passionate about leading the thought behind, wrap around, and packaging within New Zealand distribution. This is why we look beyond the package to the products, processes, and potential of our clients. And it's why we lead the way with specialised pallet wrap and packaging solutions.

Our Products

- 6 NanoWrap
- 8 NanoCore
- 9 NanoPro
- 10 NanoEcho
- 11 ClearWrap
- 12 NanoLite
- 13 Bolt™
- 14 SmartWrap/Wideweb
- 15 XT Wrap
- 16 QuickWrap
- 16 SecuraWrap
- 17 EziWrap
- 17 WeatherShield
- 18 VentWrap
- 18 ReflectorNet
- 20 Custom Cartons
- 23 Stock Cartons
- 24 Tapes & Labels
- 26 Stabulon™
- 27 PalletEssentials
- 29 PET Strapping
- 30 Mosca
- 31 OrgaPack

Our Machinery

- Spinny**
- 35 Oscar Touch V5
- 36 Zero
- 37 S140
- 38 S300
- 39 S500
- 40 S2300 Inline
- Wulftec**
- 54 WRTA150
- 55 SMH150
- 56 WCRT200
- 57 Wring250



Our Products:

We offer a superior range of pallet wrapping products thanks to our dedication to research and development.

Only by consistently looking to the needs of our customers and how best we can meet these needs can we ensure our product range can fit the pallet and fit the purpose in the most efficient and cost-effective way possible.



NANOWRAP®

We are proud to offer this high-tech, future-focused pallet wrap to forward-thinking companies around New Zealand. NanoWrap is the result of a big investment in research and development – joining multiple layers into an ultra-thin polymer required specialist expertise and technology. The result was worth it. 55 layers of high-performance wrap – a uniquely formulated film with a core formation to deliver 300% stretch capacity and maximum load stability, minimal weight and enduring peace of mind.

Features

- Load Protection.** NanoWrap delivers unrivalled performance levels in load containment and puncture resistance. Even though the overall thickness is reduced (in comparison to other packaging films) load stability is far higher.
- Eco Sustainability.** Reduce film weight by 35% and massively reduce waste and minimise potential landfill impact. With less shipping weight less fuel is needed too, making NanoWrap a win-win choice.
- Cost Savings.** The smallest gains can make a big difference in logistical costs. So when 1 metre of unstretched Nano film is stretched to 4m of wrap you're using up to 35% less product per pallet, well... those savings can be significant.



Product Options

Code	Description	Rolls/Carton	Rolls/Pallet
20412	NanoWrap 12 Machine Stretch Wrap 500mm x 2720m x 12um	1	50
20415	NanoWrap 15 Machine Stretch Wrap 500mm x 2175m x 15um	1	50
20416	NanoWrap UVA Machine Stretch Wrap 500mm x 2175m x 15um	1	50
20417	NanoWrap 17 Machine Stretch Wrap 500mm x 1920m x 17um	1	50
20420	NanoWrap 20 Machine Stretch Wrap 500mm x 1630m x 20um	1	50
20477	NanoWrap EW Machine Stretch Wrap 750mm x 1920m x 17um	1	55
20480	NanoWrap EW Machine Stretch Wrap 750mm x 1630m x 20um	1	55

The Nano Advantage

Nano = 175
500mm x 1920m x 17um

Standard = 138
500mm x 2025m x 20um

More
pallets wrapped
per roll

A closer look. Strength in unity.

While not obvious on the surface level once you put NanoWrap under the microscope you'll see the difference in quality. Each of the three Nano layers are less than 1% of the overall film thickness, providing incredible strength without adding to the bulk or weight of the film.

Conventional blown film **3 layers** NanoWrap cast film **55 layers**

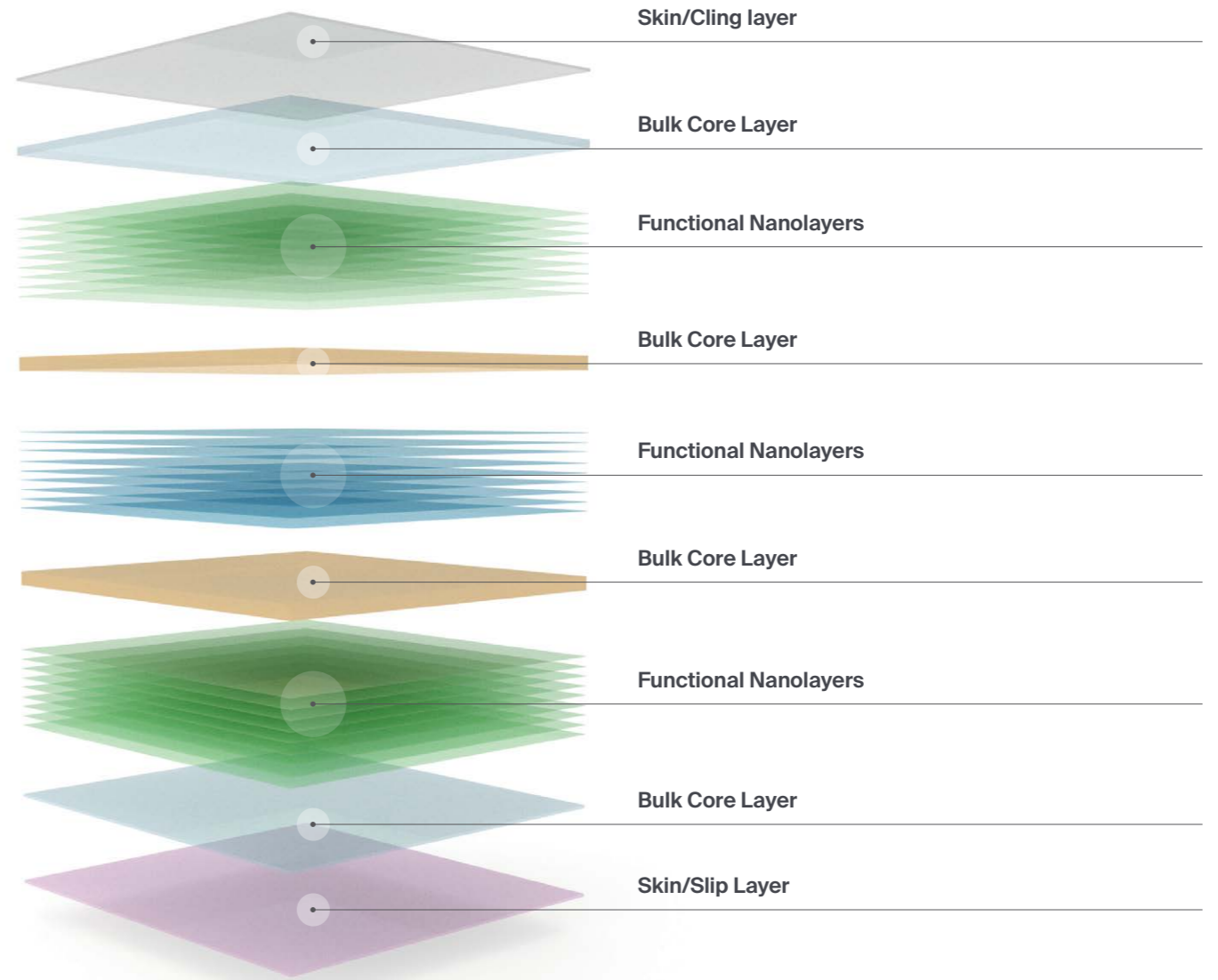

Our Products



NANOCORE

Machine ready. NanoCore performs best on medium-speed wrapping machines, operating within an optimum pre-stretch range of 200% to 300%. It works efficiently with uniform-shaped loads, delivering reliable load stability when applied correctly. Strong puncture and tear resistance combine with cost-effective pricing to provide an economical film that balances performance and practicality.

Features

Optimised Performance. Engineered to run within a 200% to 300% pre-stretch range, NanoCore delivers consistent film yield without overcomplicating machine settings. This sweet spot allows operators to maximise film efficiency while maintaining dependable containment force across each pallet.

Designed for Uniform Loads. NanoCore performs exceptionally well on uniform, stable load profiles. When paired with the correct wrapping pattern and tension, it secures pallets with confidence, reducing movement in transit and helping maintain presentation on arrival.

Reliable Strength, Smart Economics. With solid puncture and tear resistance, NanoCore stands up to the everyday demands of warehousing and distribution. Its balanced construction provides dependable protection at a competitive price point, making it a practical, high-value solution for operations focused on both performance and cost control.



15-20um



100% Recyclable

Universal Packaging
In, on & around the pallet



Product Options

Code	Description	Rolls/Carton	Rolls/Pallet
20515	NanoCore Machine Stretch 500mm x 2175m x 15um	1	50
20517	NanoCore Machine Stretch 500mm x 1920m x 17um	1	50
20520	NanoCore Machine Stretch 500mm x 1630m x 20um	1	50



Universal Packaging
In, on & around the pallet



NANOPRO

NanoPro is built for ultra-high-performance wrapping, combining the trusted benefits from the Nano range with enhanced tear propagation and puncture resistance. Now you can wrap at speed with confidence, knowing the film won't break under pressure. NanoPro is the go-to choice for achieving sustainability targets – because fewer breakages mean less waste and more savings.

Features

- NanoPro can be pre-stretched by the wrapper while still retaining enough thickness to be applied to a difficult load under tension.
- NanoPro is the choice for global distribution centers wrapping needing superior load containment, ensuring unstable or lightweight pallets stay secure from wrap to delivery
- The 67 layer film takes the best resins to give the ultimate in stretch, puncture and clarity
- 300-400% stretch allows the nanofilm to be used to it's optimum providing the highest levels of load memory and film force
- With improved puncture resistance, NanoPro protects against sharp edges and rough handling during transit.
- Consistent quality performance means every roll of NanoPro delivers reliable results, every time.



Product Options

Code	Description	Rolls/Carton	Rolls/Pallet
20413	NanoPro Machine Stretch Wrap 500mm x 2500m x 12um	1	50



Made from 30% recycled material, and with 55 layers of stretch and strength, NanoEcho quite simply delivers more protection while using less plastic.



Features

Waste reduction. Choosing NanoEcho makes a huge difference to the overall waste stream both in pre-use and post-use of the advanced film. This allows NZ companies to reduce their carbon emissions to meet and surpass sustainability goals.

Advanced construction. The innovative manufacturing technique joins multiple layers into an ultra-thin polymer. This process delivers 55 nano-layers of strength and provides greater stretch and containment force while using less plastic and keeping weight to a minimum.

Load protection. With a comparable film weight to NanoWrap, and similar stretch and containment properties, NanoEcho provides consistently superior performance and puncture resistance when compared to traditional stretch film.

55 Layers

30% Recycled Content

100% Recyclable

Product Options:

Code	Description	Rolls/Carton	Rolls/Pallet
20487	NanoEcho Machine Stretch Wrap 500mm x 1920m x 17um	1	50

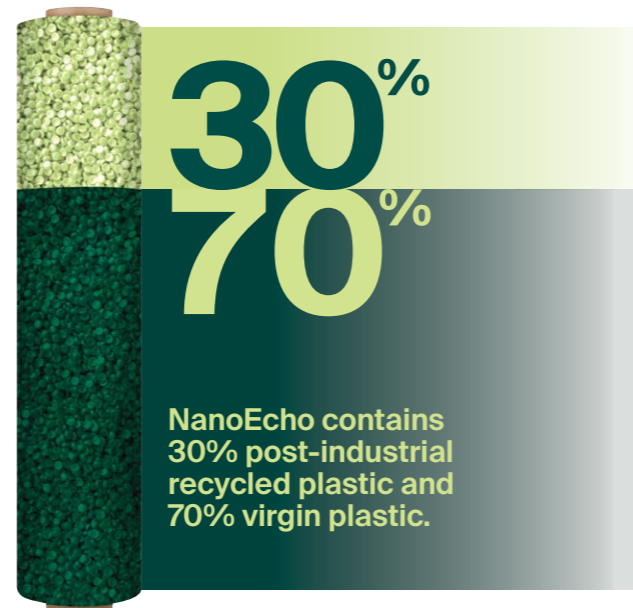

An ultra-clear, hybrid cast film offering superior elasticity, higher puncture resistance and excellent stretch memory. With these benefits you can easily identify and scan wrapped products, maximise the value per wrap and ensure stable and secure pallets long after wrapping has been completed. For peace and quiet when wrapping, and peace of mind as your goods are stored and transported, the choice is clear.



Features

- Elasticity:** Outstanding stretch guarantees up to 300% yield per roll. Maximise your value per wrap while keeping the cost per pallet down.
- Cling:** Specially formulated one sided cling means wrap clings to itself but not the neighbouring pallets.
- Memory:** Excellent elastic memory; means guaranteed pallet integrity, keeps loads stable and secure during transport and long after film is applied.
- Clarity:** Crystal clear film ensures top quality presentation, ease of product identification and barcode scanning.
- Low Noise:** Super quiet unwind allows application near offices and telephones.
- Quality Assured:** Manufactured for the New Zealand market under ISO 900 1:200 certificate and is FDA approved.

Banding increases airflow on hot products to help eliminate condensation



Product Options

Code	Description	Rolls/Carton	Rolls/Pallet
20006	ClearWrap20 Hand Stretch Wrap 500mm x 350m x 20um	6	180
20002	ClearWrap23 Hand Stretch Wrap 500mm x 400m x 23um	4	160
20049	ClearWrap15 Machine Stretch Wrap 500mm x 2700m x 15um	1	40
20051	ClearWrap18 Machine Stretch Wrap 500mm x 2250m x 18um	1	40
20052	ClearWrap20 Machine Stretch Wrap 500mm x 2025m x 20um	1	40
20054	ClearWrap23 Machine Stretch Wrap 500mm x 1750m x 23um	1	40
20059	ClearWrap30 Machine Stretch Wrap 500mm x 1350m x 30um	1	40
20078	ClearWrap30W Machine Stretch Wrap 600mm x 1350m x 30um	1	40



**Lite weight innovation.
Heavyweight performance.**

Our superior NanoLite film is up to 50% thinner than other products on the market. This thin gauge significantly reduces the volume of film needed to securely wrap pallets, reducing plastic usage considerably. It's a highly effective and sustainable hand wrapping solution for the planet – and the most sensible choice for your business.



Features

- Lightweight cardboard core, reducing waste and environmental impact.
- Pre-stretched to provide exact application tension, resulting in optimum load holding force.
- Tough 33 nano-layer technology, delivering robust film with superior containment force.
- LLDPE recycle code 4, ensuring film is fully recyclable.
- Reinforced folded edge for additional load containment, eliminating tearing from the edge.

Product Options:

Code	Description	Rolls/Carton	Rolls/Pallet
Designed for use with the BOLT dispenser.			
20221	NanoLite Hand Wrap 380mm x 480m x 5um	8	288
20222	NanoLite Hand Wrap 380mm x 320m x 7.4um	8	288
Designed with two-inch cores for hand use.			
20455	NanoLite Hand Wrap 430mm x 600m x 5.5um	6	156
20457	NanoLite Hand Wrap 430mm x 450m x 7.4um	6	312
20459	NanoLite Hand Wrap 430mm x 400m x 9.0um	6	312



Lightning speed. Leading safety.

The BOLT dispenser is the safest way to hand wrap pallet loads of goods. There's no awkward bending, no walking backwards and tripping hazards, no tricky stretching, and no knuckle grazing or friction burns. With the feather-light but sturdy design comes simplicity in use. There's no more guesswork needed to wrap with the correct tension. The BOLT is NZ's go-to hand-wrapping tool. It's safe. It's easy. And it's seriously fast.



Features

- Reliable tension** A clever torque limiter ensures consistent tension without placing unnecessary pressure on the film core.
- Magnetic attraction** An optional retrofittable magnet secures the BOLT to a forklift or pallet racking when you're on the go.
- Smart design** Additional tension adjustment and an ergonomic curved handle makes ongoing operation incredibly easy.
- Superior grip** The optional foam handle grip enhances comfort so operators can avoid callouses.
- A foot up** An optional foot means you can place it directly on the floor ready for the next pallet.
- Fast reloading ease** The unique quick-release feature is designed for easy roll replacement to reduce unnecessary downtime.
- Built-tough performance** A strong, lightweight drop-resistant frame and tensioning knob means it will take the knocks and keep on wrapping.

Product Options:

Code	Description
20220	BOLT Hand Wrap Dispenser





For the intelligent choice in wrapping SmartWrap provides all the strength for your pallets with a fraction of the wrap. That's thanks to the smart resins and state-of-the-art technology within production of the advanced wrap, a process that ensures, when compared to standard wrap products, you can wrap the same amount of pallets with 50% less film. When you need greater load stability, easy-use and less time wasted with your wrapping, wise up with SmartWrap.

Features

- Less is More.** Double your output and save up to 50% on your film consumption.
- Plus all the features and benefits of ClearWrap**
- Cling** Specially formulated inside cling means wrap clings to itself but not the neighbouring pallets.
- Memory.** Excellent elastic memory; means guaranteed pallet integrity, keeps loads stable and secure during transport and long after film is applied.
- Clarity.** Crystal clear film ensures top quality presentation, ease of product identification and barcode scanning.
- Low Noise.** Super quiet unwind allows application near offices and telephones.
- Quality Assured.** Manufactured for the New Zealand market under ISO 900 1:200 certificate and is FDA approved.

Product Options

Code	Description	Rolls/Carton	Rolls/Pallet
20278	SmartWrap Hand Stretch Wrap 500mm x 550m x 9um, Elite	4	200
20280	SmartWrap Hand Stretch Wrap 500mm x 400m x 12um, Premium	4	200
20282	SmartWrap Hand Stretch Wrap 500mm x 350m x 15um, Ultra	4	200
20283	SmartWrap Hand Stretch Wrap 500mm x 300m x 17um, Tough	4	200



SmartWrap WideWeb jumbo rolls are ideally suited to 'lights out' manufacturing areas where minimal operator input is required. WideWeb format film is preferred when products are approximately the same in height and generally uniform in shape. Only four to six rotations are required to secure most loads; rolls changeover is generally reduced to one change per shift; and pilferage, loss and breakage are dramatically reduced.

SmartWrap WideWeb

Features

- Speed.** Wrap pallets with less equipment revolutions and less time needed, ensuring you can send goods out the door quickly and efficiently.
- Size.** The large size and tough construction makes this product ideal for wrapping large objects that require tall pallet loads.
- Cost savings.** SmartWrap WideWeb is also helpful for wrapping regular sized pallet loads to save on film and energy costs.

Product Options

Code	Description	Rolls/Pallet
20290	SmartWrap WideWeb Machine Stretch Wrap, 120kg Roll 1400mm x 7750m x 12um	6



With heavy-duty reinforced edges and incredible stretch capability XTWrap makes it exceptionally easy to make excellent savings when hand wrapping. There's greater comfort – it's designed for walk-forward application and the lightweight, aerated roll reduces strain. There is less damage (the banded edge of the puncture-resistant film increases the holding force on the pallet). And there's greater efficiency. The reduced plastic per pallet helping minimise waste overall operating costs, savings of up to 50% less compared with conventional 20 – 23 micron film.

Features

- More comfort.** When hand-wrapping pallets many people tend to walk backwards. It's an unhealthy approach. In the short-term there's a risk of trips and falls. In the long-term it causes repetitive strain on the back. The roll is designed for walk-forward application and the lightweight, aerated roll minimises strain and effort. As an easier and safer product for hand wrapping XTWrap helps both individuals and companies step forward with confidence.
- Less breakage.** Tears in packaging film can compromise the goods on the pallet and frustrate operators. The reinforced edges prevent tears while the puncture-resistant composition of the film keeps any small rips in their place. The tougher borders also eliminate edge catch – a primary cause of tearing. The roll itself is aerated, giving it a spongy texture that also prevents damage to the film if a roll is dropped.
- Less waste.** It doesn't matter what industry you're in, chances are you're striving to minimise waste, inefficiency and overall operating costs. Reducing the amount of plastic used to wrap each pallet load can be a big step in this process. XTWrap is stronger than other wraps. Which means that less is needed to contain a pallet load. We're not talking small savings here either – it can be up to 50% less when compared with a conventional 20 - 23 micron film. So you can use half as much wrap without compromising load integrity.
- More security.** It's simple – damage to product means damage to your bottom line. When wrapped in XTWrap a pallet load is firmly and more securely contained. It's safer in transit and product damage is less likely. This security is primarily thanks to the reinforced edge. This acts like a band, allowing the wrap to grip a pallet load more firmly and increasing the overall holding force of the packaging.



Product Options

Code	Description	Rolls/Carton	Rolls/Pallet
20281	XTWrap Hand Stretch Wrap 500mm x 330m x 12um	6	192

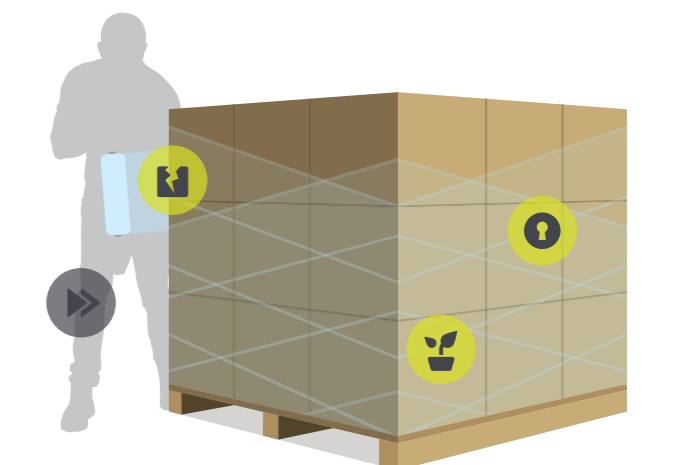

Our Products



QUICKWRAP

Sure, we could go on and on about the benefits of this film. But don't worry – we'll keep it quick. Quick and easy to handle, this revolutionary pallet wrapping film combines the qualities of the conventional ClearWrap films with the easier application properties of pre-stretch technology. QuickWrap offers minimum cost per wrap, less waste and is safe and easy to use. When you have the need for speed this wrap is a snap.

Features

- Better Value.** Having been pre-stretched, maximum yield from the roll has already been realised, ensuring a more cost effective option.
- Easier to Apply.** QuickWrap is easier to apply which increases productivity and minimises the risk of injury and strain. Pre-stretching results in an aerated roll which is lighter and softer to handle.
- Exceptional Performance.** Having been pre-stretched, maximum yield from the roll has already been realised, ensuring a more cost effective option.
- Added Value.** All rolls come packed in durable cardboard cartons to prevent dust buildup and roll damage.

Product Options

Code	Description	Rolls/Carton	Rolls/Pallet
20328	QuickWrap Pre-stretched Hand Wrap 450mm x 500m x 10um	4	192



Universal Packaging
In, on & around the pallet



SECURAWRAP

Sometimes you need to keep everything under wraps until the right time. With SecuraWrap you can conceal the contents of your cargo quickly and easily – the bright and bold wrapping effectively covering up what's inside and deterring theft during shipment. With this key strength the wrap is ideal for both protecting valuable and confidential products and quickly identifying products that are urgent, need to be used first or are perishable.

Colour Options

- Black** Generally used for concealing pallet loads of tobacco and alcohol.

Product Options

Code	Description	Rolls/Carton	Rolls/Pallet
20203	SecuraWrap Hand Stretch Wrap 500mm x 400m x 23um, Black	4	128
20255	SecuraWrap Hand Stretch Wrap 500mm x 400m x 23um, Red	4	256

Our Products



EZIWRAP

It's all 'easy does it' with our EziWrap. This bundling wrap can be used to replace tape and twine when packaging small items and, unlike tapes, it won't stick to the product or leave residue. The stretch wrap dispenser makes hand-wrapping easy too, the telescopic shaft and moulded hand-grip and top handle designed to be user-friendly across different sized rolls. With End Caps you'll also save your fingers, save time and save stress. Yes – it's that Ezi.



Hand Wrap Dispenser



Bundle Wrap

Product Options

Code	Description	Qty/Carton
22300	EziWrap Bundle Wrap 100mm x 300m x 20um	20
22302	EziWrap Heavy Duty Bundle Wrap Dispenser	1
22200	EziWrap Heavy Duty Hand Stretch Wrap Dispenser	1

Universal Packaging
In, on & around the pallet



WEATHERSHIELD

This is the ultimate all-weather wrap for your products – a specifically formulated hybrid cast stretch wrapping film designed for use on pallets that will be exposed to the elements. WeatherShield delivers all the performance standards of ClearWrap along with the all-important weather-proofing benefits, including an extra high inside cling to guard against water ingress and superior UV stabilisation. For durable and secure pallet protection you'll be packing with confidence – and singing in the rain.

Features

WeatherShield combines key weather proofing benefits:

- Waterproof.** Extra high inside cling eliminates water ingress and stops wrap unwind. Inside cling means it clings to itself but not the neighbouring pallets.
- UV Stabilisation.** With a high UV content, this film will withstand outdoor conditions for up to 18 months. Protect your products from harmful rays.

Plus all the features and benefits of ClearWrap



Product Options

Code	Description	Rolls/Carton	Rolls/Pallet
20764	WeatherShield23 Machine Stretch Wrap UV 500mm x 1500m x 23um	1	40



Our Products



VENTWRAP



This perforated stretch wrap has been carefully developed to provide perfectly vented protection for pallets of produce, dairy, beverage and frozen food. With punched holes for ventilation this wrap eliminates condensation build-up on the inside of the film and markedly reduces spoilage times – all without losing the strength and convenience of regular pallet wrap or the performance capabilities of stretch netting.

Features

- Hot Filled Products.** VentWrap prevents condensation developing avoiding associated problems such as, rust on tins or caps, discolouration of packaging & labels and impaired performance of glues.
- Frozen Products.** VentWrap shortens the freezing time as the cold air comes through to the product quicker. Also the thawing time is shortened as the moisture can escape faster.
- Fresh Produce & Plant.** VentWrap gives product protection combined with optimal air circulation contributing to longer lasting freshness.

Product Options

Code	Description	Rolls/Carton	Rolls/Pallet
20615	VentWrap Perforated Hand Stretch Wrap 420mm x 500m x 9um, Pre-stretch	6	216
20620	VentWrap Perforated Machine Wrap 500mm x 1200m x 30um	6	60

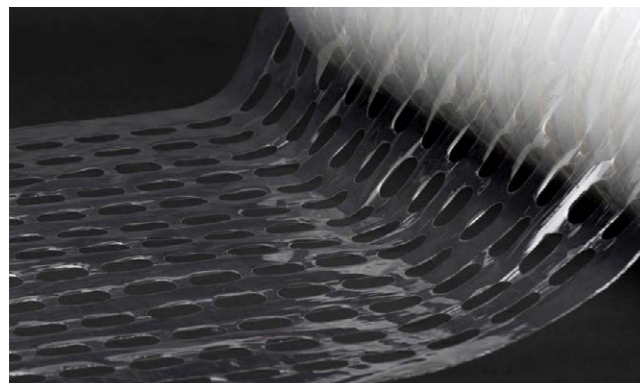

Universal Packaging
In, on & around the pallet

REFLECTORNET



A revolutionary designed super-stretch knitted pallet wrap. ReflectorNet has a unique balance of extra strength, elasticity and hold.

ReflectorNet has been engineered to give your valuable pallet load long-lasting hold, shape protection and added stability.

Features

- Agricultural & Horticultural Products.** XPRO prevents condensation while allowing produce to breathe, extending shelf life and maintaining quality.
- Food & Beverage.** XPRO controls is suitable across hot, cold, and wet pack products like fish, meat and dairy, protecting goods during storage and transport.
- Industrial Materials.** XPRO protects heavy and sharp loads while maintaining integrity and strength.
- Freight, Logistics & Pick and Pack.** XPRO improves ventilation and load stability, keeping goods protected and dry through distribution.

Product Options

Code	Description	Rolls/Pallet
20800	XPRO Hand (2" core) 50cm x 750m	200
20801	XPRO Machine (3" core) 50cm x 3000m	50
20802	XPRO Machine (3" core) 75cm x 3000m	35
20803	XPRO 110 Machine (3" core) 50cm x 2265m	40

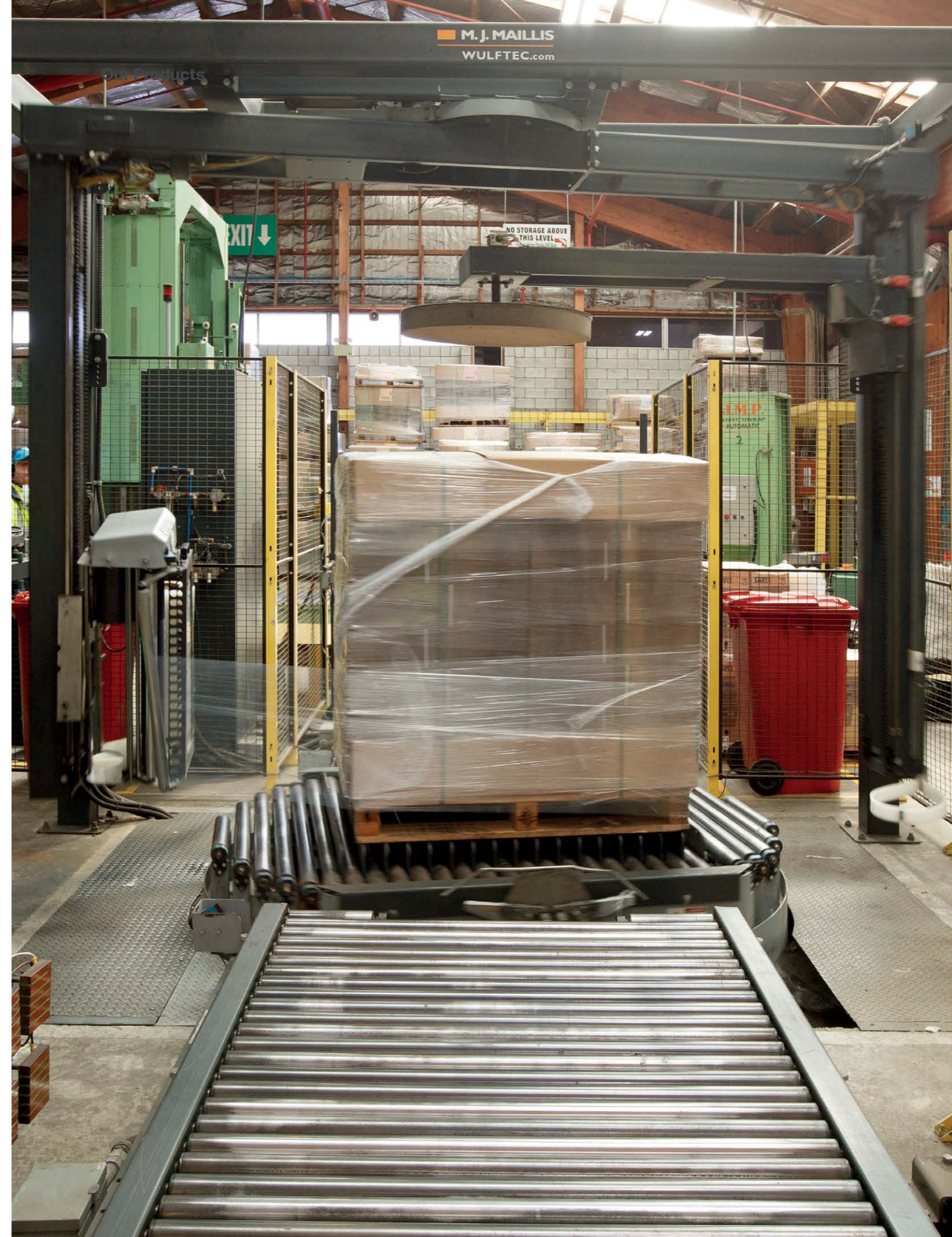

Custom cartons designed, made, stored and supplied, when and where needed.

With our collaborative supply process, every Kiwi company can have beautiful on-brand cartons, when and where they need them, without committing to on-site storage.



With over 20,000sqm of warehouse space nationwide, we can store cartons for big and small businesses throughout New Zealand.

For smaller companies who want to order customised packaging, “minimum order quantities” can seem anything but minimum. New Zealand’s carton manufacturers work in large quantities which can make a run of custom cartons prohibitively expensive.

For larger companies that require fast, efficient, and cost-effective national distribution capability, consignment ordering is incredibly helpful. These businesses may not have a central hub or sufficient storage at individual locations, but need cartons delivered quickly when stock is running low.

Carton consignment provides the supply flexibility needed. The process is simple, but effective. We source custom sized or printed cartons on your behalf, store them, and supply to you as needed.

Payment can occur only when you receive a portion of the order and includes storage, handling, and delivery. Otherwise, we offer a range of finance and logistics options – and are always happy to discuss the best way to ensure the right result for our customers.

Flexible supply

- Direct ship: one order, one delivery
- Consignment: our stock on your floor and pay as you use.
- Storage: your stock on our floor.

Run Size

- Orders large or small, from a bundle to a truck load!

Samples

- Free custom samples, try before you commit.

How does flexible supply work?



1. Design

We work with you to design a carton that best suits your product, optimises shipping rates, and promotes your brand.



2. Pricing

We are preferred wholesale partners of NZ’s largest carton manufacturers, so you get the most cost-effective deal guaranteed.



3. Security

A supply agreement formalises our commitment to supply in full and on time, every time, and your commitment to draw down on stock within the agreed period.



4. Manufacture

We order custom made cartons in volume to get the best lead times and rates.



5. Storage

The entire consignment is delivered to one of our central distribution warehouses for bulk storage.



6. Dispatch

You draw down on your stock when you require it (could be daily), saving valuable warehouse space and helping cash flow.



7. Management

We manage the ordering process on your behalf, removing the pressure of running low on stock.



8. Reporting

Clear reporting ensures you know exactly how much stock you’ve got, when a reorder is approaching, and how your delivery KPIs are tracking.



9. Sustainability

Pack with peace of mind knowing all cartons are produced sustainably and that you’re supporting responsible forest management globally.

How to design your custom carton?

While the process of designing and printing custom cartons can be easy, expertise and experience can make a big difference in delivering a superior result. Our consultant team is always ready to discuss the options and opportunities available. We can make recommendations on the size, strength quantity, and style of carton that works best for your individual requirements.



1. Style

We will help you choose the best carton style to suit your product.



2. Print

Select single or multiple colour print designs.



3. Strength

We can advise on optimum board grade to maximise strength & value.



4. Colour

Choose between Kraft and White.



5. Size

We will optimise the size to best fit your product, reducing freight costs to your business.



6. Quantity

Confirm your preferred quantity be it a pallet or a truck lot.

Stock Cartons

Our stock cartons are the strong, durable, and cost-effective way to package goods for transport, storage and distribution. Made from 100% recyclable corrugated carton board, each is easy to assemble and can be conveniently stored flat when not in use.



Recyclable



Reusable



FSC



North Island Product Options:

Code	Description	Size(mm)	Bundle
000-00NI	Size 00	154 x 142 x 102	30
000-0NI	Size 0	190 x 150 x 155	25
000-1NI	Size 1	255 x 205 x 150	25
000-2NI	Size 2	250 x 250 x 200	25
000-3NI	Size 3	340 x 255 x 305	25
000-4NI	Size 4	405 x 255 x 255	25
000-5NI	Size 5	430 x 330 x 255	25
000-6NI	Size 6	455 x 305 x 305	25
000-7NI	Size 7	455 x 455 x 350	25
000-8NI	Size 8	510 x 380 x 280	25
000-9NI	Size 9	510 x 380 x 585	25
000-9NI30C	Size 9 A30C	510 x 380 x 585	25
000-10NI	Size 10	610 x 290 x 290	25
000-14NI	Size 14	598 x 344 x 231	25
000-HA4S	Size Half A4 Small	305 x 215 x 105	30
000-A4S	Size A4 Small	305 x 215 x 200	30
000-A4NI	Size A4	310 x 225 x 250	30
000-A4DNI	Size A4 Deep	310 x 220 x 305	30
000-A3NI	Size A3	424 x 312 x 152	25
000-SRA3NI	Size SRA3	468 x 334 x 315	30
000-A2NI	Size A2	600 x 425 x 100	30

South Island Product Options:

Code	Description	Size(mm)	Bundle
001-86SI	Size 86	186 x 140 x 130	25
001-1SI	Size 1	250 x 250 x 200	25
001-2ASI	Size 2A	280 x 173 x 195	25
001-2SI	Size 2	250 x 250 x 368	25
001-82SI	Size 82	300 x 200 x 160	25
001-3SI	Size 3	303 x 303 x 250	25
001-4SI	Size 4	340 x 255 x 305	25
001-4BSI	Size 4B	375 x 260 x 170	25
001-5SI	Size 5	405 x 255 x 255	25
001-6SI	Size 6	430 x 330 x 255	25
001-7SI	Size 7	455 x 305 x 305	25
001-8SI	Size 8	457 x 457 x 356	25
001-9SI	Size 9	510 x 380 x 280	25
001-10SI	Size 10	510 x 380 x 585	25
001-11SI	Size 11	610 x 290 x 290	25
001-12SI	Size 12	305 x 217 x 305	20
001-14SI	Size 14	254 x 203 x 152	25
001-15SI	Size 15	450 x 340 x 150	25
001-16SI	Size 16	478 x 321 x 356	25
001-17SI	Size 17	500 x 500 x 450	25
001-20SI	Size 20	406 x 216 x 117	10
001-A4SHSI	Size Half A4 Small	305 x 215 x 105	25
001-A4S	Size A4 Small	305 x 215 x 200	25
001-A3SI	Size SRA3	450 x 320 x 255	25

Brand your tape





Custom printed tape is an economical and effective way to get your message out there. Stay on brand by adding your company logo, protect your goods from damage with an important storage or handling message, or take the opportunity to do something a little more interesting and memorable for those receiving your goods.

How to order:

 Create your design

 Pick your roll direction

 Choose your repeat lengths

 Submit your artwork

Our custom printed tape is made with top quality adhesives and high-definition print. Available in a range of different base colours, lengths, and adhesives, they provide the perfect brand solution for Kiwi companies.

Tapes & Labels



Packaging Tape. Stay sure of your sending. These economical, high-quality pressure-sensitive tapes are used for sealing corrugated cartons. Made from a polypropylene backing with an acrylic or rubber adhesive, they are available in both standard and low noise options.

Message Tape. Where specific handling instructions are required, message tape can be the perfect tool to do the job. Instruct recipients to 'Handle With Care', that the items within are 'Fragile', or are subject to a 'Security Seal' - with customised messaging available too.

Labelopes. Keep things clear with this fast and easy method for shipping information (such as packing slip enclosed, invoice enclosed etc).

Features & Benefits:

- Cost effective
- Superior quality
- Low noise tape options available

The Specs:

- 24-48mm standard width tape rolls
- Clear or brown standard packaging tapes
- Coloured/printed tapes available on request
- Custom sizes available



Economical



Premium



Customisable

Packaging Tape

Stay sure of your sending. These economical, high-quality pressure-sensitive tapes are used for sealing corrugated cartons. Made from a polypropylene backing with an acrylic or rubber adhesive, they are available in both standard and low noise options.



Code	Description	Rolls (mm x m)	Carton
411-48100CLH	General Purpose Hand Tape	48 x 100	36
411-481500CLM	General Purpose Machine Tape	48 x 1500	4
411-FG24100CL	Tape FPA3 Clear Premium Freezer Grade	24 x 100	36
411-E36100CL	Tape S99C Clear Economy	36 x 100	48
411-E48100BR	Tape S93B Brown Economy	48 x 100	36
411-PFG48100CL	Tape S100 Clear Premium Freezer Grade	48 x 100	36
411-48100STCL	Tape Supatape Clear Low Noise	48 x 100	36
411-48100RA	Tape S30 Rubber Adhesive	48 x 100	36

Message Tape

Where specific handling instructions are required, message tape can be the perfect tool to do the job. Instruct recipients to 'Handle With Care', that the items within are 'Fragile', or are subject to a 'Security Seal' - with customised messaging available too.



Code	Description	Rolls (mm x m)	Roll/Carton
413-SEC48100	Security Seal	48 x 100	6/36
413-FRAG48100RW	Fragile - Red/White	48 x 100	6/36
413-REPACK48100	Repack	48 x 100	6/36

Label on a roll

Label on a roll is ideal for labelling and sealing products where specific packaging instructions are required. Available in Fragile, Handle With Care, Security Seal and more.



Code	Description	Rolls (mm x m)	Roll
414-75100F	Fragile - Orange/Black	72 x 100	660
414-75100HWC	Handle with care - Orange/Black	72 x 100	660
414-75100TS	Top Stow - Orange/Black	72 x 100	660
414-75100TWU	This Way Up - Orange/Black	72 x 100	660
414-75100U	Urgent - Orange/Black	72 x 100	660
414-7575DC	Don't Crush - Orange/Black	72 x 100	660

Labelopes

Keep things clear with this fast and easy method for shipping information (such as packing slip enclosed, invoice enclosed etc).



Code	Description	Rolls (mm x m)	Box
410-115150IE	Invoice Enclosed	115 x 150	1000
410-115150PSE	Packaging Slip Enclosed	115 x 150	1000
410-PLAINA4	Plain A4	332 x 235	500
410-PLAINA5L	Plain A5 Large	235 x 175	500
410-PLAINDOC	Plain Document	115 x 150	1000

Stabulon™



STABULON™ anti-slip paper sheets reduce stacked product layers shifting during shipping and handling. Thanks to the high coefficient (up to 42°) on both sides, slippage and damage issues can become a thing of the past.

- Recycled paper coated 2 sides
- High non-slip properties
- Rigid
- 100% recyclable
- ISO 14062 Eco-designed certified
- Tertiary packaging, indirect food contact
- Stabilize any packaging format
- Manual and automated applications
- Available in two weights.



Product Options

Code	Description	Per/Pallet
22670	Stabulon 100, 2 Side 1000mm x 1200mm 100gsm	250

PALLET ESSENTIALS

The individual strengths of our PalletEssentials range certainly adds up to deliver the total pallet package. We hold standard stock products and also manufacture customised products to individual requirements. That means, be it for top covers, top sheets, shrouds and hoods, bin liners, base and layer sheets, or corner boards, we've got you covered.



Pallet Top Covers

Perforated sheets of plastic film on a roll to protect the top of palletised goods and large articles from dirt, rain and other damage during transit. A good tamper deterrent also. Top covers are supplied perforated on a roll. Dependent upon volume, custom made sizes, grades and colours are also available upon request.



Product Options

Code	Description	Rolls/Carton	Rolls/Pallet
22709	Pallet Top Covers, Natural, 250/roll 840/1680mmW x 1680mmL x 16um	1	25
22700	Pallet Top Covers, Natural, 250/roll 840/1680mmW x 1680mmL x 20um	1	36
22702	Pallet Top Covers, Black, 250/roll 840/1680mmW x 1680mmL x 20um	1	36
22705	Pallet Top Covers, Natural, 250/roll 1000/2000mmW x 2000mmL x 20um	1	25
22720	Pallet Top Covers, Natural, 100/roll 1050/2100mmW x 3000mmL x 50um	1	20

Pallet Top Sheets

Pallet Top Sheets come as a continuous single wound sheet (SWS) for fully automated machine application and are often custom made to suit the client's machine.



Product Options

Code	Description	Rolls/Carton	Rolls/Pallet
22810	Pallet Top Sheets, SWS, Natural 1600mmW x 500mL x 50um	1	20
22845	Pallet Top Sheets, SWS, Natural 1800mmW x 420mL x 50um	1	20
22805	Pallet Top Sheets, Hole Punch 1600mmW x 500mmL x 30um	1	30
22840	Pallet Top Sheets, SWS, Natural 1800mmW x 760mmL x 40um	1	20
22841	Pallet Top Sheets, SWS, Natural UV 1800mmW x 230mL x 75um, 185mm core	1	20

Pallet Shrouds

Heavy duty heat shrinkable and non-shrinkable pallet shrouds, used to provide a secure, puncture and weather resistant covering for unstable, heavy/irregular shaped products. Supplied perforated on a roll for ease of application. Also custom made on request in a range of sizes, thickness and colours.



Product Options

Code	Description	Rolls/Carton	Rolls/Pallet
23007	Pallet Shroud , Natural, 1100 x 900 x 1800mm, 30um	1	100
23010	Pallet Shroud , UV Plain, 1270 x 1070 x 1900mm, 125um	1	20
23016	Pallet Shroud , 1250 x 1250 x 1600mm, 30um	1	100

Pallet Base

Pallet Base and Layer Sheets offer protection from water, dirt or dust. Made from heavy corrugated cardboard, PE Coated Kraft paper or non-slip plastic, pallet sheets are placed either on the base of a shipping pallet before the goods are placed on top, between layers of product offering stability and further protection or on top of a shipping pallet to protect the goods underneath.

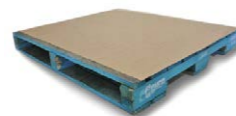

Product Options

Code	Description	Per/Pallet
22602	Pallet Base Sheet , 415B Board Grade 1200 x 1000mm	-
008-FTC1812	Corrugated Sheet , Twin Cushion brown sheets 1200 x 1800mm	-

Pallet Corner Boards

Using Cardboard Corner Boards (edge protectors) avoids costly damage to products in transit or storage. They provide greater stacking strength when pallets are double or triple stacked, eliminate shifting loads and stabilise strapped or stretch-wrapped loads.



Product Options

Code	Description	Per/Pack
209-VI50502004	Corner Boards 4mm thick 50mm x 50mm x 200mm	250
209-VI50509704	Corner Boards 4mm thick 50mm x 50mm x 970mm	25
209-VI505010004	Corner Boards 4mm thick 50mm x 50mm x 1000mm	25
209-VI505012004	Corner Boards 4mm thick 50mm x 50mm x 1200mm	25
209-VI505014004	Corner Boards 4mm thick 50mm x 50mm x 1400mm	25
209-VI505019304	Corner Boards 4mm thick 50mm x 50mm x 1930mm	25

Bin & Carton Liners

Leak-proof and food safe, they are widely used as bulk bin or carton liners in the food manufacturing and distribution industry. Ideal for protecting and transporting meat, fish, poultry, seafood, or finished baked goods, they can also be used as heavy-duty pallet bags or crate liners to keep goods clean and protected.



Product Options

Code	Description	
323-FS4	Carton Liner , FS4, High Density, 425 x 300 x 450mm x 16um	1000(Carton)
323-FS6T	Carton Liner , FS6, High Density, 635 x 375 x 660mm x 16um	600(Carton)
23020	Bin Liners , Natural 1270mm x 1070mm x 3000mm x 70um	30(Roll) / 25(Pallet)

PET Strapping

PET Strapping is the polyester strap you can rely on to bind right and stay strong. Tougher than polypropylene and more economical than steel strapping, it keeps integrity and retains tension for ideal load stability. It's tough (even penetration by errant nails won't stop it), it's safe and it's easy to apply - there are no sharp edges and it can be used by hand or with automated machinery.



Product Options

Code	Description	Rolls/pallet
42005	PET Machine Strapping 9mm x 0.65mm x 3200m Embossed surface, Breaking strain: 210kg	20
42031	PET Hand Strapping 16mm x 1.0mm x 1000m Green Smooth, Breaking Strain 600-650kg	24
42032	PET Hand Strapping 16mm x 1.0mm x 1100m Green Embossed, Breaking Strain 570-620kg	24
42033	PET Machine Strapping 12mm x 0.62mm x 2500m Green Embossed, Breaking Strain 230 - 270kg	24
42034	PET Machine Strapping 19mm x 1.0mm x 900m Green Embossed, Breaking Strain 750-800kg	24



PET Strapping Dispenser

Keep your pallet PET Strapping in reach and at hand with this fast, easy and efficient dispenser. While lightweight in design it has stay-tough construction, ensuring long-term strapping peace of mind.



Product Options

Code	Description
42003	PET strapping dispenser Strong, lightweight, easy to use with wheels, handle and tool storage.



MOSCA®

Mosca® is renowned internationally for the strength and integrity within their product range. Their strapping is one of the key reasons for this reputation – its lightweight useability and heavyweight durability making it a major winner for Kiwi companies everywhere.

With standard blue polypropylene machine strapping and hand application strapping available, as well as clear, black and white strapping, there are plenty of available options to meet your specific requirements. We can also provide a range of tools and accessories available to assist with applying this strapping.



Features & Benefits:

- Strong & flexible
- Durable & lightweight
- Various breaking strain options available
- Available in standard & heavy duty
- 5 - 12mm widths
- Useful for bundling products together & palletising

Code	Description	Thickness	Unit	Break Strain
500-123000BLM	Mosca PP Strapping 0.55mm - Blue	12mm	3000m	110kg
500-57000BKM	Mosca PP Strapping - Black	5mm	7000m	55kg
500-56500WH	Mosca PP Strapping .40um - White	5mm	6500m	TBC

Accessories

Code	Description	Suits	Thickness	Pack
501-PB12	Buckle Plastic	12mm PP	12mm	1000
501-PB19	Buckle Plastic	19mm PP	19mm	1000
501-MB13LB	Buckle Metal	12mm PP	13LB	2000
501-MB19CB	Buckle Metal	19mm PP HD	19CB	1000
501-MS19HD	Seal Metal	19mm PP	19HD	1000
501-SC19	Strapping Crimper	19mm PP		

ORGAPACK

The OrgaPack range of strapping equipment is well respected internationally for some very good reasons. First there is the well-balanced design, ensuring day after day of stress-free use. Then there's the functionality. Users have strap alignment measurements, favourite strapping mode, real time indication of applied tension force and variable tension speed control – all within easy reach and at the touch of a finger.



OR-T 140

Lightweight ease: Fast, easy and effortless, the OR-T 140 provides lightweight binding capability for functional pallet strapping.

OR-T 270

Everyday reliability: With proven performance and ideal hand-held balance, the durable design and practical functionality of the OR-T 270 makes it the most popular strapping tool around the world.

OR-T 460

Heavy-duty strength: Delivering an incredible 400-4500N of tension force the OR-T 460 is at the top of game for hand-held-in-control strapping capability.

	OR-T 140 Light	OR-T 270 General	OR-T 460 Heavy
Strap type	PET + PP	PET + PP	PET + PP
Strap width	9 - 13 mm	13 - 16 mm	16 - 19 mm
Strap thickness	PET: 0.4 - 0.8 mm; PP: 0.5 - 0.8 mm	0.5 - 1.0 mm	0.8 - 1.3 mm
Weight	3.6 kg	3.8 kg	4.3 kg
Tension force	150 - 1200 N	400 - 2500 N	400 - 4500 N
Variable Tension Speed	0 - 290 mm/s	0 - 220 mm/s	0 - 120 mm/s
Cycles / Charge	up to 800	up to 800	up to 800
Battery	Bosch Li-Ion 18V, 2.0Ah	Bosch Li-Ion 18V, 2.0Ah	Bosch Li-Ion 18V, 4.0Ah
Charging time battery	15 - 30 min	15 - 30 min	25 - 35 min
Motor technology	Single motor technology, brushless	Single motor technology, brushless	Single motor technology, brushless
Dimension (L x W x H)	370 x 141 x 135 mm	370 x 141 x 135 mm	370 x 143 x 135 mm



Our Machinery:

With our international network and specialist partners we provide big and small New Zealand businesses with advanced wrapping technology – the kind of equipment that saves time, money and stress with every pallet wrapped.

Our Spinnny machines provide the answer to all your hand wrapping issues. With speed, precision and ongoing reliability they wrap up, wrap fast and wrap right. Our Wulftec equipment delivers high-end wrapping versatility and functionality. When it comes to quantity and quality this technology leads the way.

Machine wrapping. What's right for you?

There are many reasons why businesses wrap pallets by hand. Often a machine is seen as too expensive, or operations are loathe to change the systems that have "always worked". Sometimes, with the range of technology available and uncertain needs, there's reluctance to commit to a specific machine. Here are some key considerations for assessing the change.



Damaged goods.

Products will move under loose or poorly applied wrap and not even the most experienced of hand-wrappers can wrap a pallet as firmly or consistently as a machine.

Machine-tensioned plastic wrap also becomes more puncture and tear-resistant as it's stretched, creating a holding power far superior to hand-stretched wrap. Have damage costs on hand when assessing what's right for you.



Plastic waste.

How many layers of film does it take to stabilise a bulky or awkward pallet by hand? And how many rolls of film get nicked or damaged as they're thrown around? We regularly put such systems to the test and can confidently share the answer: it's a lot.

A machine will apply exactly the right amount of film at the right tension, with less damage to film rolls. That's how this equipment soon pays for itself in plastic film reduction alone (we test for that too).



Labour costs.

Hand wrapping pallets is time consuming and inefficient. A machine will consistently wrap a pallet faster. This frees up staff to deliver the next one – or to complete other tasks as the cycle completes. Throughput is increased significantly by semi-automating the wrapping process.



Health and safety risks.

With a lot of bending, twisting and pulling from the operator, awkward movements that invite over-use or strain injuries, hand-wrapping is tiring, repetitive and potentially risky. Companies are now increasingly aware of these health and safety risks – and automating the wrapping process is one way of making the job easier, safer and more enjoyable.

Oscar Touch V5

Motorized Pre-Stretch Pallet Wrapping Robot

Built for flexibility and efficiency, the Oscar Touch V.5 delivers high-performance pallet wrapping without the constraints of a fixed machine. As a mobile wrapping robot, it moves effortlessly around your warehouse, wrapping palletised loads of any size, weight or shape with precision and consistency. This makes it an ideal solution for operations where space is limited or pallet locations are constantly changing.

With its intuitive touchscreen controls and programmable wrap cycles, the Oscar Touch V.5 removes the guesswork from pallet wrapping while reducing the need for manual handling.

Operators can quickly set and repeat optimal wrap patterns, ensuring every load is securely wrapped and ready for safe transport.

Efficiency gains extend beyond labour savings. Equipped with a motorised pre-stretch carriage, the Oscar maximises film yield while maintaining strong load containment. This reduces material usage, lowers costs, and supports more sustainable operations.

For businesses handling heavy, standard or high-volume pallet loads, the Oscar Touch V.5 provides a smart, mobile solution that improves productivity, enhances safety, and keeps your warehouse moving.



All dimensions in (mm)

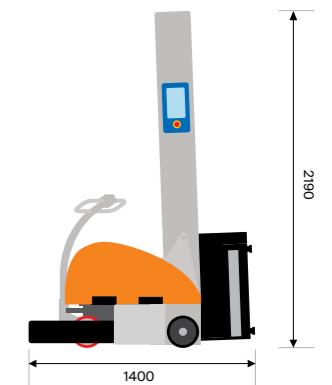
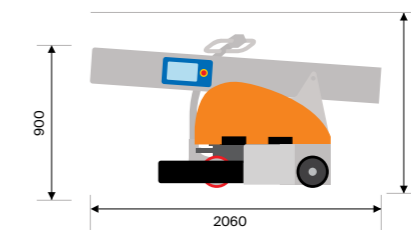

Ideal for:

- Warehouses and distribution centres with limited space
- Wrapping heavy pallet loads (2000kg+)
- Operations looking to reduce manual handling
- Mobile wrapping across multiple pallet locations

Custom Options:

- Safety laser scanner
- Wrapping height upgrade to 2600mm or 3100mm
- Black products photocell
- Anti-theft taping system
- Automatic film cutting system at end of cycle
- Double contact wheel
- Lithium battery version available

Features

- The motorized pre-stretch system is a special device that ensures the use of the ideal amount of film.
- Film carrier equipped with motorized pre-stretch system up to 250%
- Quality Italian design and construction
- Wrapping height automatically detected by photocell
- Independent top and bottom reinforcement wraps
- Separate film tension adjustment at any cycle position
- Intermediate reinforcement with adjustable height and number of turns
- End-of-cycle and film breakage signal
- 12 customizable wrapping programs
- Adjustable speed with smooth start/stop
- Complete charging cycle: 8 h with AGM batteries / 3 h with Lithium battery (chargers on board)

Specifications

Film system: Motorized pre-stretch

Standard pre-stretch ratio: 200%

Optional pre-stretch ratios: 100%, 150%, 250%

Minimum package size: 600 x 600mm

Standard wrapping height: 2100 to 2200mm

Optional wrapping heights: 2600mm, 3100mm

Speed: Up to 1.33 m/s

Film carriage speed: 3 to 5 m/min

Machine weight: 250kg

SPINNY ZERO

Semi Automated Stretch Wrapper

Ready to 'zero out' hand wrapping from the end of line packaging equation? To reduce labour and save costs this introductory Spinny model provides the perfect answer.

As an entry level up-and-down stretch wrapper the Spinny Zero is a good fit for small distribution centres looking to improve their end-of-line efficiency and reduce the health and safety risks associated with hand wrapping pallets.

It'll wrap pallets up to 1200kg to the standard height of 2100mm and operators can also add extra layers of wrap for more stability with heavier products. Replacing hand-wrapping is the first step toward more efficient end-of-line packaging systems. The countdown is on – get to Zero.

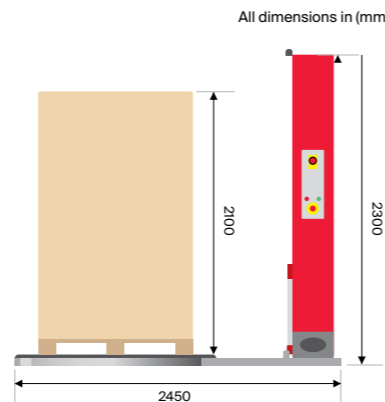
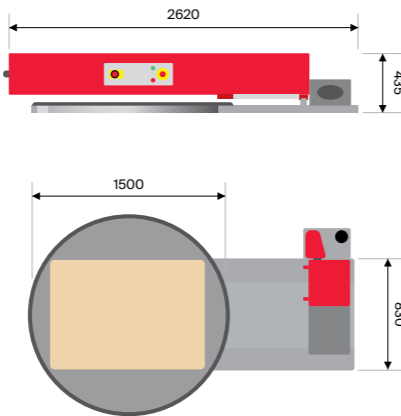

Ideal for:

- Small-scale distribution or storage facilities
- Small or infrequent dispatches
- Wrapping products that travel easily
- Securing pallets of a consistent weight and shape
- Budget-conscious distribution centres

Custom Options:

- Smart touch control panel with 4 customisable wrapping programs
- Turntable diameter up to 2200mm
- Wrap height up to 3800mm
- Load cell and monitor
- Ramp

Features

- 1 year factory warranty
- Quality machinery made in Italy
- Variable rotating speed from 6 to 12 rpm with gradual rotation start/stop
- Indexed turntable returns to start
- Photo cell for automatic load height detection
- Electronic control panel with four programmable wrapping cycles
- Single phase operation
- Full service maintenance plans
- Fast, nationwide parts backup
- Excellent after sales support and operator training

Specifications

Turntable Diameter	1500 mm
Turntable Capacity	2000 kg
Distance between mast and turntable	500 mm
Wrap Height Detected by photocell	2100 mm
Turntable Speed	0 to 12 rpm
Production Rate Per hour	25 loads
Power Supply	Single Phase
IP Rating	44 – 65
Load Size	1200 x 1000mm

SPINNY S140

Semi Automated Stretch Wrapper

Get some go-forward with our most popular semi-automated turntable wrapper. The S140 simplifies packaging solutions for distribution centres with specific containment requirements.

When wrapping pallet loads that vary in shape, weight or configuration, the S140 is a great player to have on your team. It applies exactly the right amount of film at a consistent tension – which means big savings on wrap costs and less damage to product.

The semi-automation of this equipment is a big draw-card. Operators can program four different wrap cycles to deal with diverse loads. By varying the tension, speed, number of wrap layers and top/bottom reinforcements they can ensure each pallet load is secured, no matter the mix of products.



S140 with slotted turntable

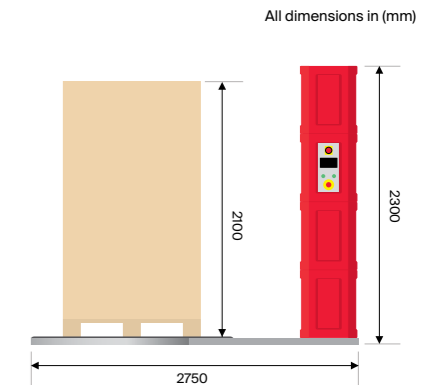
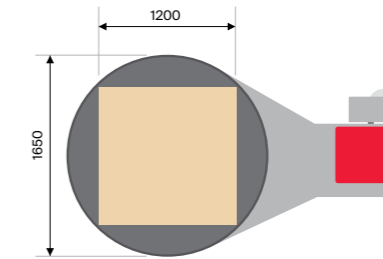

Ideal for:

- Medium-sized distribution or storage centres
- Frequent or concentrated dispatch cycles
- Companies seeking to reduce health and safety risks
- Securing fragile loads e.g. wine, beer and other breakables
- Wrapping heavy goods e.g. liquids, chemicals and resins

Custom Options:

- Slotted base for pallet trolleys
- Turntable diameter up to 2200mm
- Mast extension from 2600 - 3100mm
- Weigh scale and digital monitor
- Ramp

Features

- 3 year factory warranty
- Made in Italy to rigorous quality standards
- Soft start and stop turntable function
- Indexed turntable returns to start
- Photo cell for automatic load height detection
- Electronic control panel with four programmable wrapping cycles
- Full service maintenance plans
- There-when-you-need-it parts backup
- Excellent after sales support and operator training

Specifications

Turntable Diameter	1650 mm
Turntable Capacity	2000 kg
Distance between mast and turntable	500 mm
Wrap Height Detected by photocell	2100 mm
Turntable Speed	0 to 16 rpm
Production Rate Per hour	25 loads
Power Supply	Single Phase
IP Rating	44 – 65
Load Size	1200 x 1200mm

SPINNY S300

Semi Automated Stretch Wrapper Powered pre-stretch film carriage

For pallet packaging that requires a little more muscle, the S300 is ready to do the heavy lifting. With a powered carriage that can pre-stretch wrap by up to 300% you'll get firmly wrapped pallets with a lot less film.

This power in packaging capability saves most operators between 40% - 50% in film costs, providing the Spinny S300 with a healthy ROI for larger-scale distribution centres that already do a lot of wrapping.

As opposed to a conventional application system, machine-tensioned film allows light or unsteady loads to be wrapped securely and consistently. Operators with diverse wrapping requirements can conveniently program up to five wrap cycles to cater for all load possibilities. Sound like something that will spin your wheels? Read on for all the details...



Spinny with weigh scale

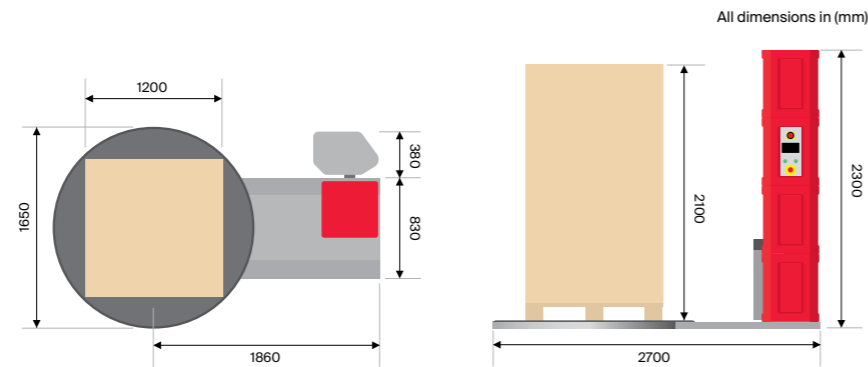

Ideal for:

- High volume distribution centres
- Optimising inventory management
- Wrapping very light, very heavy or unstable pallets
- Unpredictable pallet loads

Custom Options:

- Slotted base for pallet trolleys
- Turntable diameter up to 1800mm
- Mast extension from 2600 - 3100mm
- Weigh scale and digital monitor
- Ramp

Features

- Powered pre-stretch film carriage 200%-300%
- 3 year factory warranty
- Quality Italian design and construction
- Soft start and stop turntable function
- Indexed turntable returns to start
- Photo cell for automatic load height detection
- 5 Lockable programs to stop operator interference
- Full service maintenance plans
- Fast parts backup for ongoing peace of mind
- Superior post-sales support and operator training

Specifications

Turntable Diameter	1650 mm
Turntable Capacity	2000 kg
Distance between mast and turntable	500 mm
Wrap Height Detected by photocell	2100 mm
Turntable Speed	0 to 16 rpm
Production Rate Per hour	25 - 35 loads
Power Supply	Single Phase
IP Rating	44 - 65
Load Size	1200 x 1200mm
Prestretch standard	200%

SPINNY S500

Automated Stretch Wrapper Powered pre-stretch film carriage

With no need for an operator to start and finish the wrap cycle the S500 provides exceptional savings in labour costs - making this the logical choice for money-spinning pallet wrapping on a large scale.

With a device that automatically clamps, cuts and seals the wrap, the S500 removes the need for manual intervention when wrapping pallets. A forklift driver simply has to deliver a pallet to the turntable and set it in place. They're then freed up to get the next one while it's wrapped.

The cost savings from increased efficiency don't end there. Equipped with a power pre-stretch carriage, big savings on plastic film are possible with the S500. The pre-stretched film also allows light and unsteady loads to be firmly wrapped for safe dispatch.

For large-volume centres the savings made on labour and film costs alone will quickly offset the investment in the S500. Also important - the safety risks associated with the manual elements of the storeperson's role are virtually eliminated.



All dimensions in (mm)



Fully automated clamp, film cutting device and film tail heat sealer.

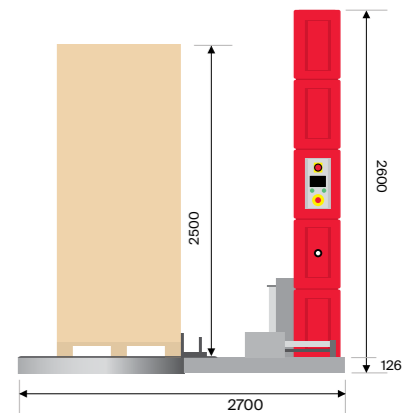
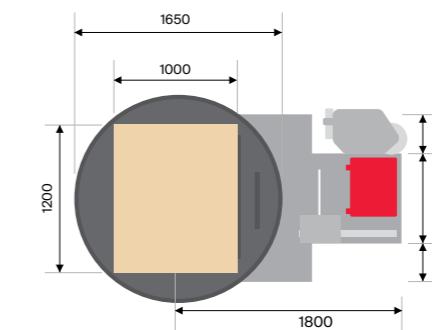

Ideal for:

- Supermarkets, food or perishables storage
- Starting the automation process
- Flow optimisation
- Reducing forklift use
- Improving productivity of warehouse staff

Custom Options:

- Slotted base for pallet trolleys
- Turntable diameter up to 1800mm
- Mast extension up to 3100mm
- Weigh scale and digital monitor
- Silent compressor
- Ramp

Features

- Powered pre-stretch film carriage 200% - 300%
- 3 year full factory parts warranty
- Quality Italian design and construction
- Fully automated film clamp, film cutting device and film tail heat sealer
- Touch screen control panel giving 10 programmable wrapping options ability to lock programs to stop operator interference
- Soft start and stop turntable function
- Indexed turntable returns to start
- Photo cell for automatic load height detection
- Fork slots in base for ease of relocation

Specifications

Turntable Diameter	1650 mm
Turntable Capacity	2000 kg
Distance between mast and turntable	500 mm
Wrap Height Detected by photocell	2500 mm
Turntable Speed	0 to 16 rpm
Production Rate Per hour	35 - 45 loads
Power Supply	Single Phase
IP Rating	44 - 65
Load Size	1200 x 1000mm
Prestretch standard	200%

SPINNY S2300 Inline

Automated Stretch Wrapper

Fast, safe and hyper-efficient, the fully automated S2300 production wrapper's powered in-and-out feed conveyors keeps things moving from A to B with no DIY or extra OT needed.

Take the people out of the packaging process and keep things powered up and moving along with the Spinny S2300 – an innovative new pallet packaging unit that can handle every load you throw (or roll) at it.

Wrapping between 50 and 70 loads an hour means that throughput is prodigious. The spinning doesn't need to stop and, thanks to the convenience of the conveyor, it doesn't have to.

Being able to pre-stretch wrap by up to 300% means that considerable ongoing costs can be made with packaging budgets, and the rapid return on investment is certainly a motivating factor for many Kiwi companies.

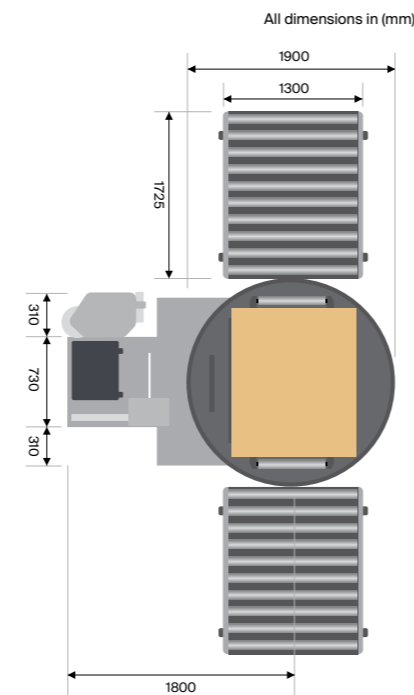
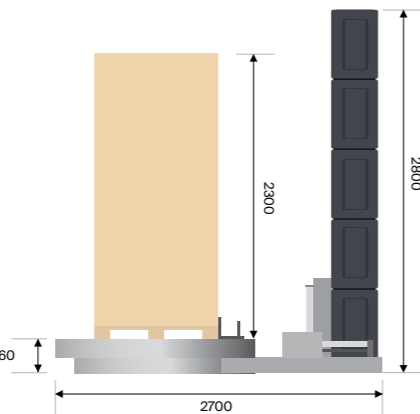

Ideal for:

- Production lines
- Reducing labour and forklift use
- Flow optimisation
- Improving productivity

Custom Options:

- Additional conveyors
- Intergrated safety system
- Top cover applicator
- Silent compressor

Features

- Powered film carriage provides 200% - 300% pre-stretch
- Production rate per hour: 50-70 loads
- Quality equipment made in Italy
- 3 year factory warranty
- Fully automated film clamp, welding and film cutting device.
- Soft start and stop turntable function
- Indexed turntable returns to start
- Power supply – 3 Phase
- Photo cell for automatic load height detection
- Touch screen control panel giving 10 programmable wrapping options
- Touch screen control panel offers ability to lock programs to stop operator interference
- Full service maintenance plan
- Parts backup when and where you need it

Specifications

Turntable Diameter	1900 mm
Turntable Capacity	2000 kg
Distance between mast and turntable	500 mm
Wrap Height	2300 mm
Detected by photocell	
Turntable Speed	0 to 16 rpm
Production Rate Per hour	50 – 70 loads
Power Supply	3 Phase
IP Rating	44 – 65
Load Size	1200 x 1200mm
Pass Height	460mm
Prestretch standard	200%

Service made simple. Technical Spinny support.

The last thing you want to be thinking about is your equipment breaking down. Yet over the lifetime of a stretch wrapper machine things will occasionally go wrong – with any mechanical equipment managing this much throughput it's hardly unexpected.

That's why, when you factor in lost productivity waiting for replacement parts, the cheapest machine will probably not cost the least.

Service support.

We've developed our support system over the years to ensure we can deliver expertise when you need it, be it at the end of a phone or on site with the machine.

Our in house service technicians and network of proven and trusted service agents throughout New Zealand also provide fast repairs, routine maintenance and service checks on pallet wrappers, and they respond to emergency call outs when you need fast assistance.

Spare part speed.

The Spinny range uses a high proportion of non-proprietary components. We also stock a full range of spare parts ready for immediate dispatch. So Spinny operators know that production downtime is kept to a minimum should anything need replacing.

This is the after-sales service commitment that everyone at Universal Packaging is proud of. We know that in the art and science of logistics there can be millions in the millimetres. So there must be cents (and sense) in the servicing, parts and repair equation too.

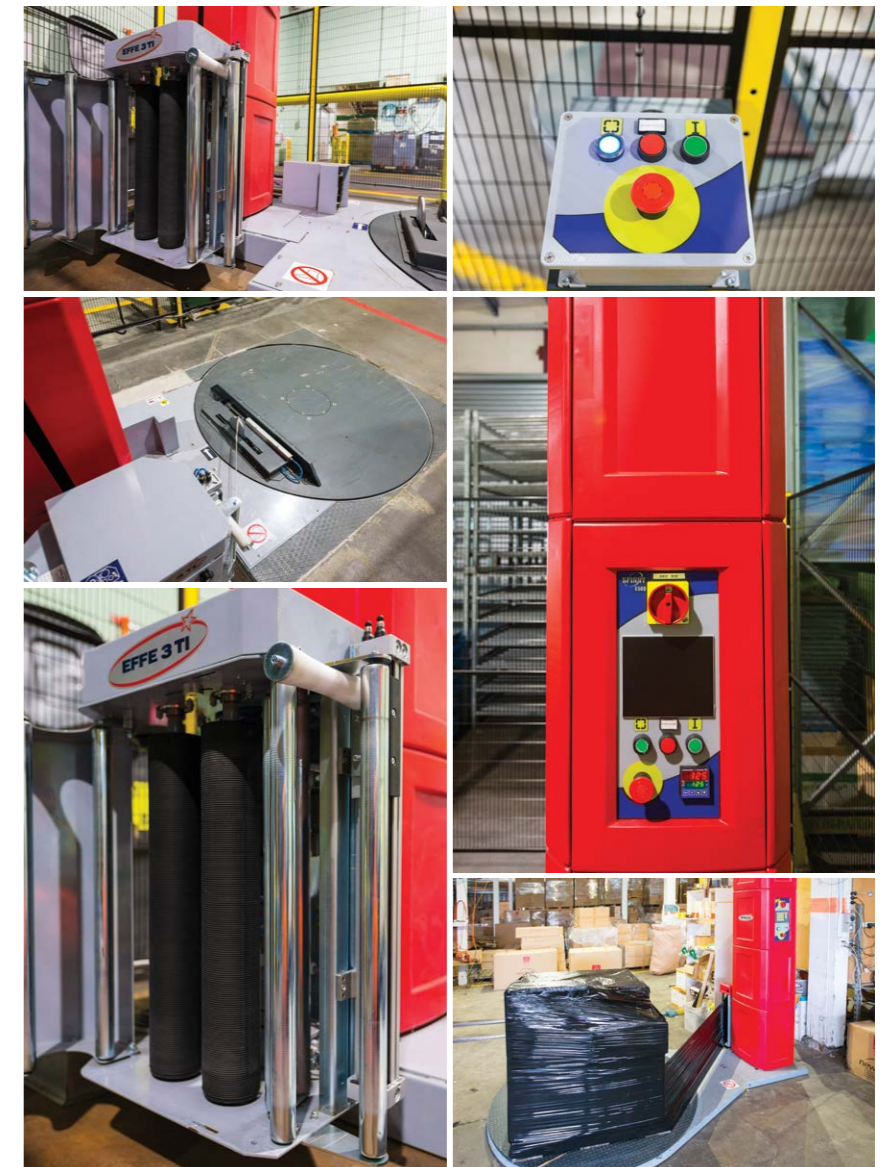

Equipment layout

Yes, a Spinny unit will certainly increase the efficiency of your distribution. But it's not the only way we'll help ensure your pallet wrapping performance is kept at its peak.

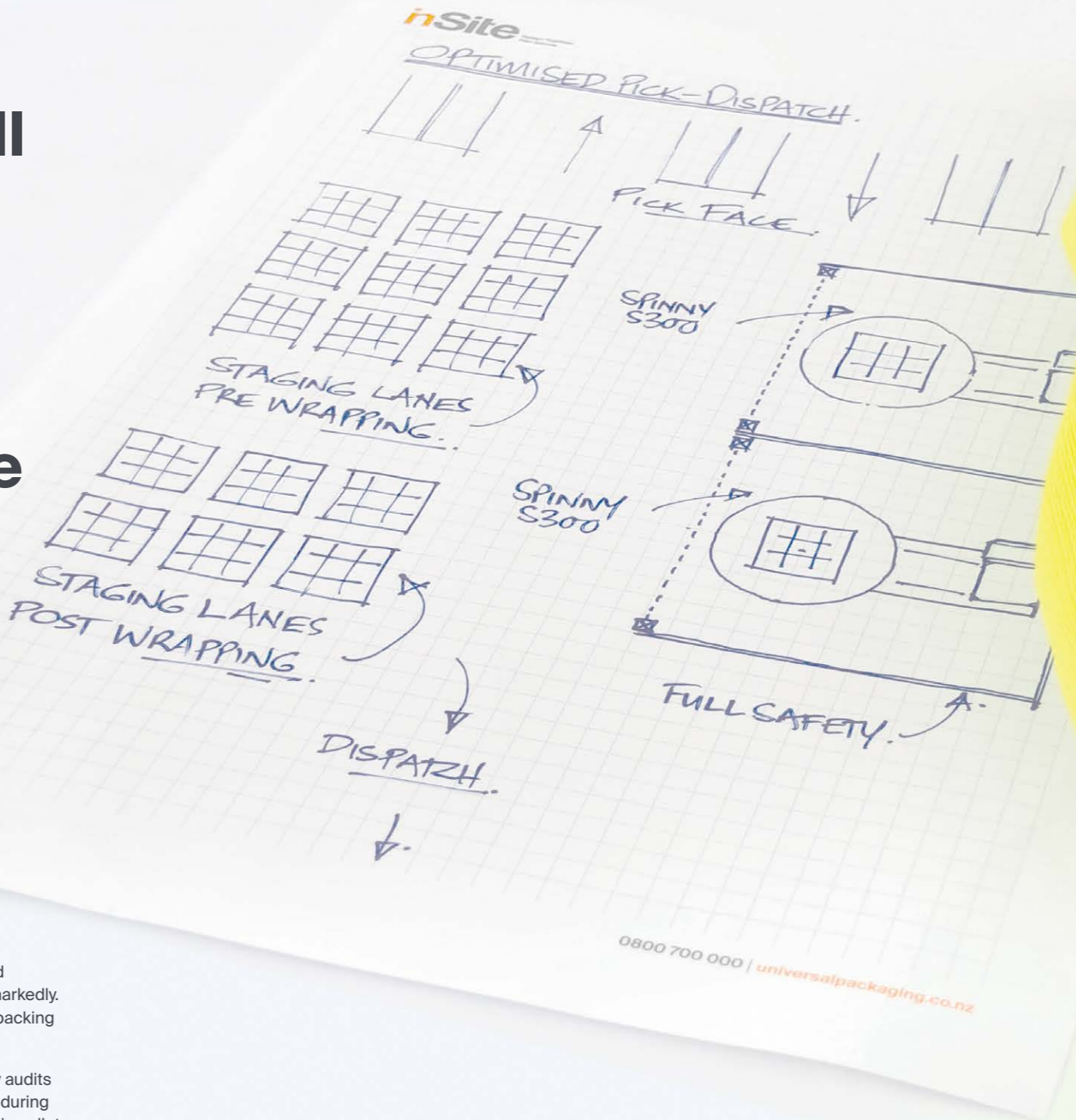

If you're moving from hand-wrapping to semi-automated, or semi-automated to full automation, the change will potentially free up floor space and, in doing so, create new opportunities for streamlining movement and processes.

Moving to a semi automatic wrapper delivers complete control on the tension and performance of wrap. When compared with hand wrapping there is less variation in human movement around the wrapper and greater options for spacing of staging areas.

Moving to a full automatic wrapper means there is less time and less movement involved in wrapping a pallet. Whole

staging areas can be freed up and productivity levels can increase markedly. More product can be stored and packing efficiency increased.

We also provide on-site efficiency audits to many of our customers before, during and after any big change is made in pallet wrapping. Small tweaks here and there can have big consequences in time and cost savings in the future.

Our Technical Sales team also has the expertise to assess wrapping settings and modify them to ensure maximum yield per roll of wrap, and we can back this up with remote film monitoring too.

Safety systems: new and retrofitted.

It's not just a case of 'better safe than sorry'. Nowadays you need to be better and smarter with your safety.

The dangers from heavy loads and moving parts can provide much more than logistical headaches. Physical safety is in the spotlight now more than ever and every New Zealand distribution facility needs to ensure things are done right each and every time.

There is no one-size-fits all safety solution however. In product, people and process no two distribution centres are the same. That's why we take an individual-Universal approach, carefully assessing every element of the operation around your Spiny equipment before making a recommendation on what type of system to use.

One of the biggest elements of any operation is also one of its most challenging to address – everyday human behaviour.

When we design a safety system we have to make sure it doesn't hinder productivity.

Otherwise, human nature being like it is, people will try to 'work around' the safety system to stay on top of the workload. Such a result is entirely counter-productive.

Keeping an expert eye on both the safety engineering and ongoing productivity requirements is crucial, especially for our work retrofitting systems.

With these systems we can deliver ideal safety of team members while maintaining maximum pallet wrap efficiency and minimal red tape anxiety. Importantly too, we can also scope, design and install these systems quickly without affecting your everyday pallet throughput.

Key considerations for installing safety systems

- How does the system protect individuals without increasing individual workloads?
- How many fail-safes are required before the system becomes unwieldy or confusing?
- How do physical barriers work with the operation of equipment?
- How can everyone leave at the end of the day in the same condition they arrived?

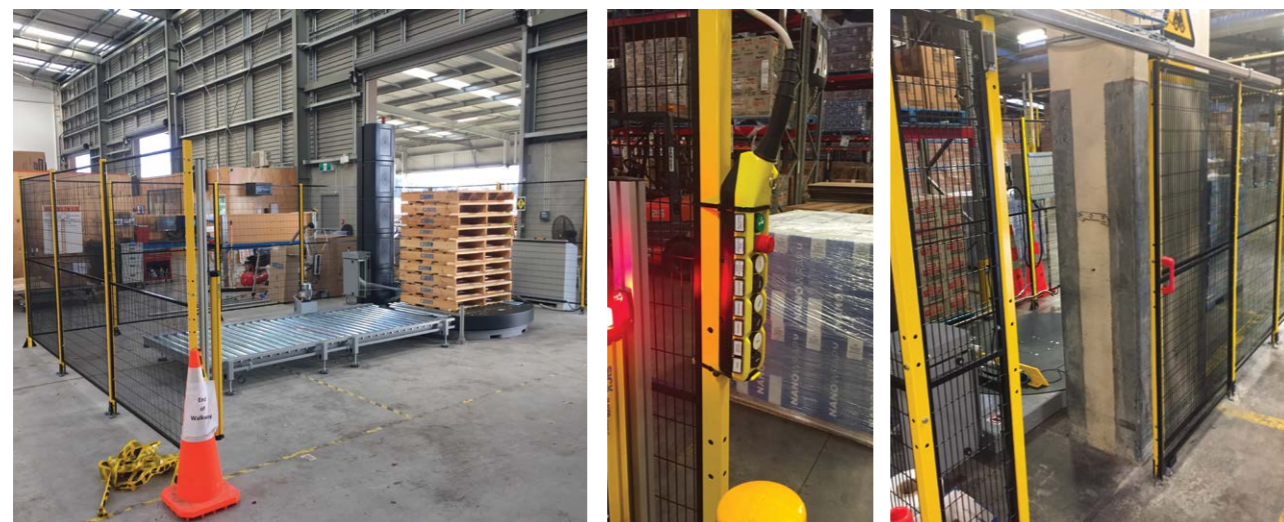

Purchase options

No distribution facility is ever quite the same, and budgetary requirements vary markedly from business to business.

That's why we have developed a range of payment and lease options to suit the many different sizes and operational styles of our customers. So there's no reason why a Spiny unit can't be helping to reduce waste and cut costs in the immediate future.

1: Purchase outright

2: Lease to Own

3: Lease

4: Short-term hire

5: Free on loan

6: Purchase via product use

Specific lending criteria, payment arrangements and timeframes apply to each of these options. If you'd like to know more about any of these finance choices get in touch with one of our team at:

sales@universalpackaging.co.nz
0800 700 000



Go with the flow

Unwieldy layouts and ineffective planning can often compromise the valuable real estate within a typical distribution centre. These inefficient, labour-intensive wrap processes inflate costs and increase the potential for product damage.

There's a better way. Thanks to our carefully scoped design and the best in technological capability we can make the most of your every square metre. With our help you can optimise the pick to dispatch process, reduce waste and save time and costs.

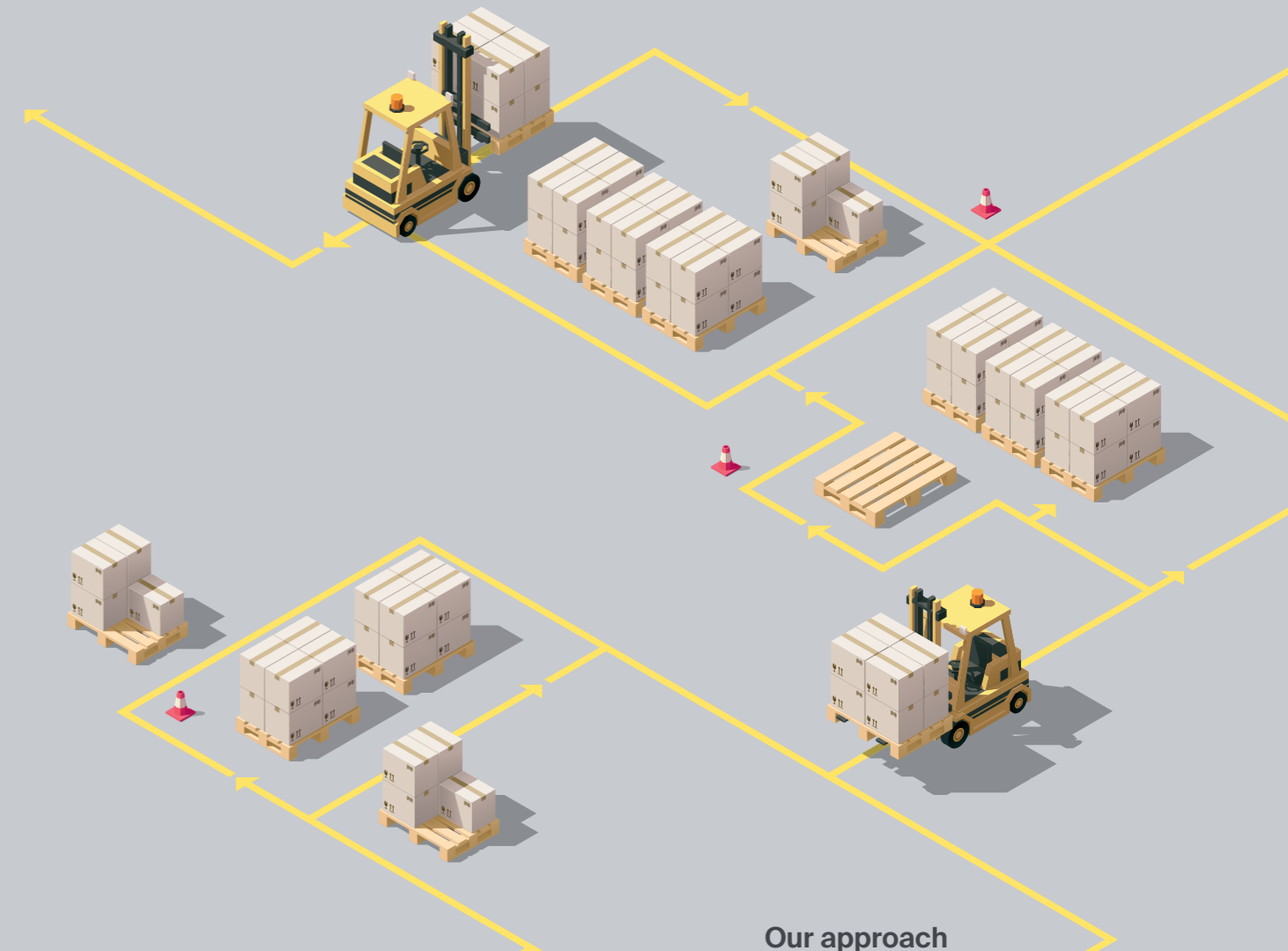
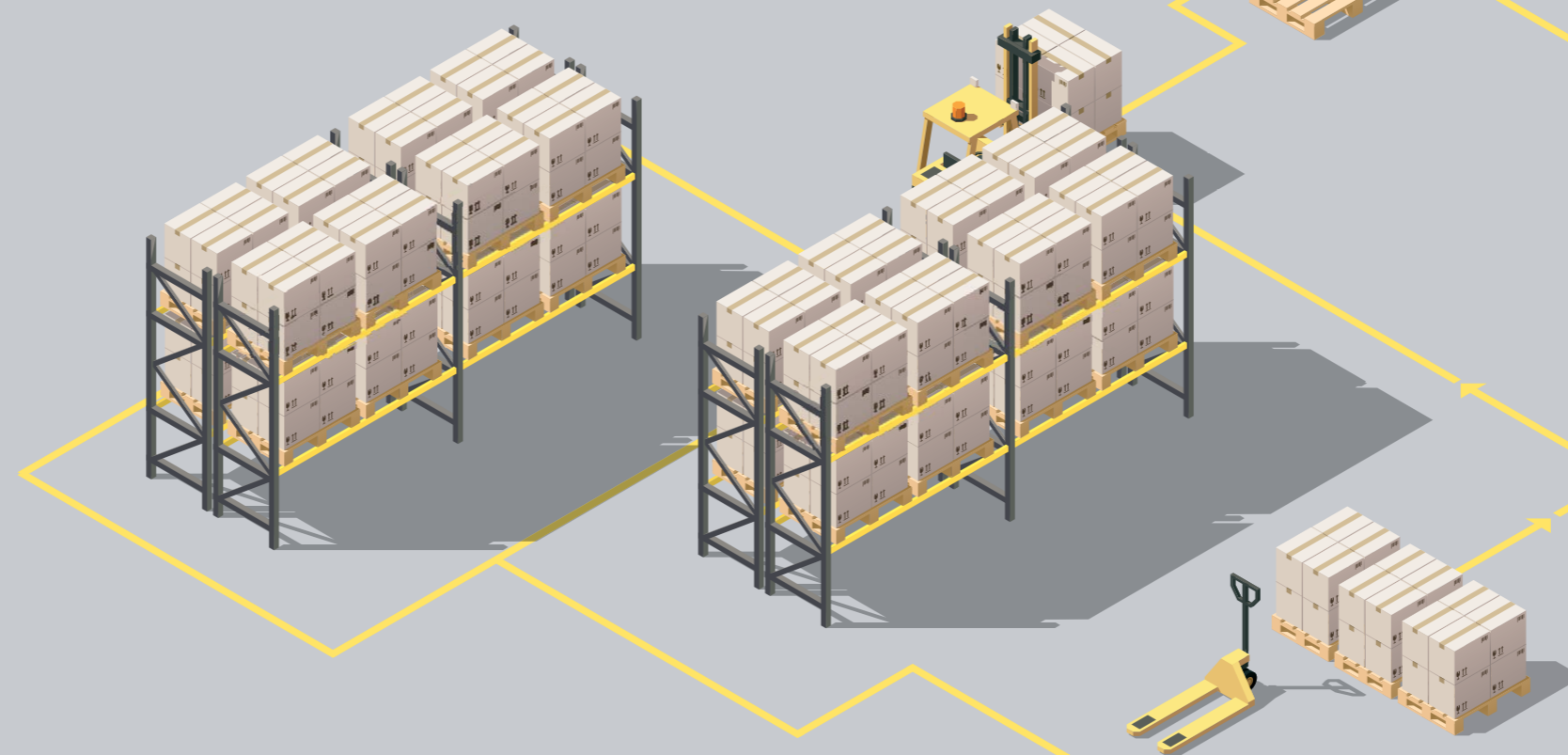

Our approach

In 2013 we undertook Australasia's first ever installation of dual floor-mounted rotary arm Wulftec stretch wrappers. Since then we've been busy developing a range of systems to suit an equal range of packaging needs.

During this time we've also travelled the world increasing our expertise. Only in this way can we ensure New Zealand's companies can effectively increase their pallet output, save space and increase throughput using the very best of wrapping technology.

When companies are shipping considerable amounts of goods each day there can effectively be 'millions in the millimetres'.

We take the time to carefully scope and measure each and every potential Wulftec installation. If we can't prove considerable gains with a new system we won't recommend it.

Thanks to our SCOPE technology these gains can be quickly seen and correctly maintained. Your peace of mind in our packaging efficiency is our primary focus.

Traditional Process

The traditional distribution centre requires plenty of labour and individual equipment units.

With this amount of equipment, significant safety processes are required, meaning additional space around each and every moving part. Goods are handled multiple times as pallets make the way from the stack to the truck. Every pick up and put down turns seconds into minutes into hours of lost productivity.

Traditional pick to dispatch

Labour/equipment requirements

1. Picking	 x1	 x1	
2. Unwrapped Staging	 x1	 x1	 50-100m ²
3. Wrapping	 x2	 x1	 20-30m ²
4. Wrapped Staging	 x1	 x1	 50-100m ²
5. Dispatch	 x1	 x1	

*Typical traditional warehouse set up in New Zealand

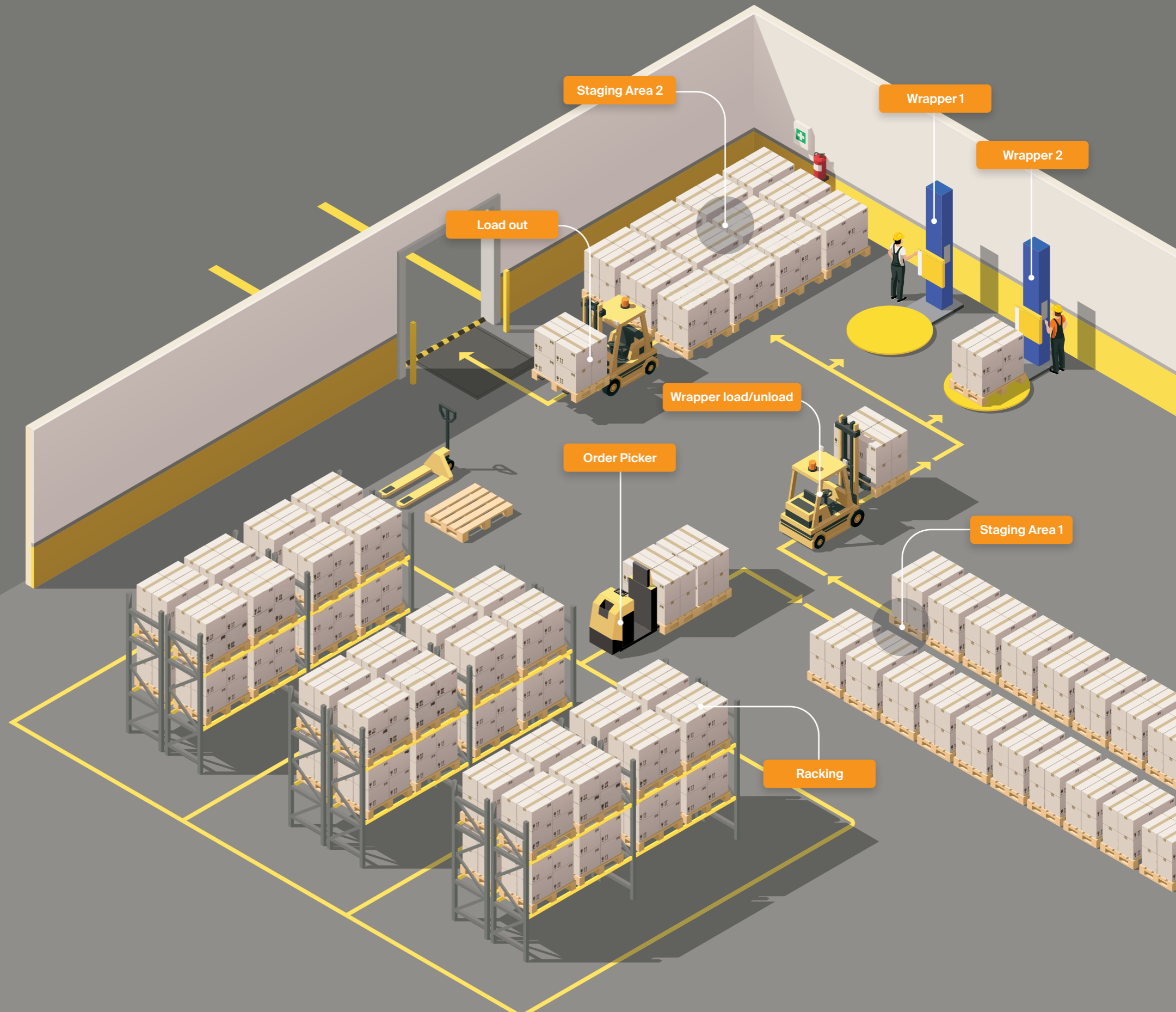

Optimised Process

We help scope and improve equipment positioning, staging areas and other key zones to ensure everything is working at its best.

Less travel saves time and also creates greater efficiencies in fuel use and equipment replacement. That's how small tweaks to your set-up can turn centimetres of change into kilometres of savings.

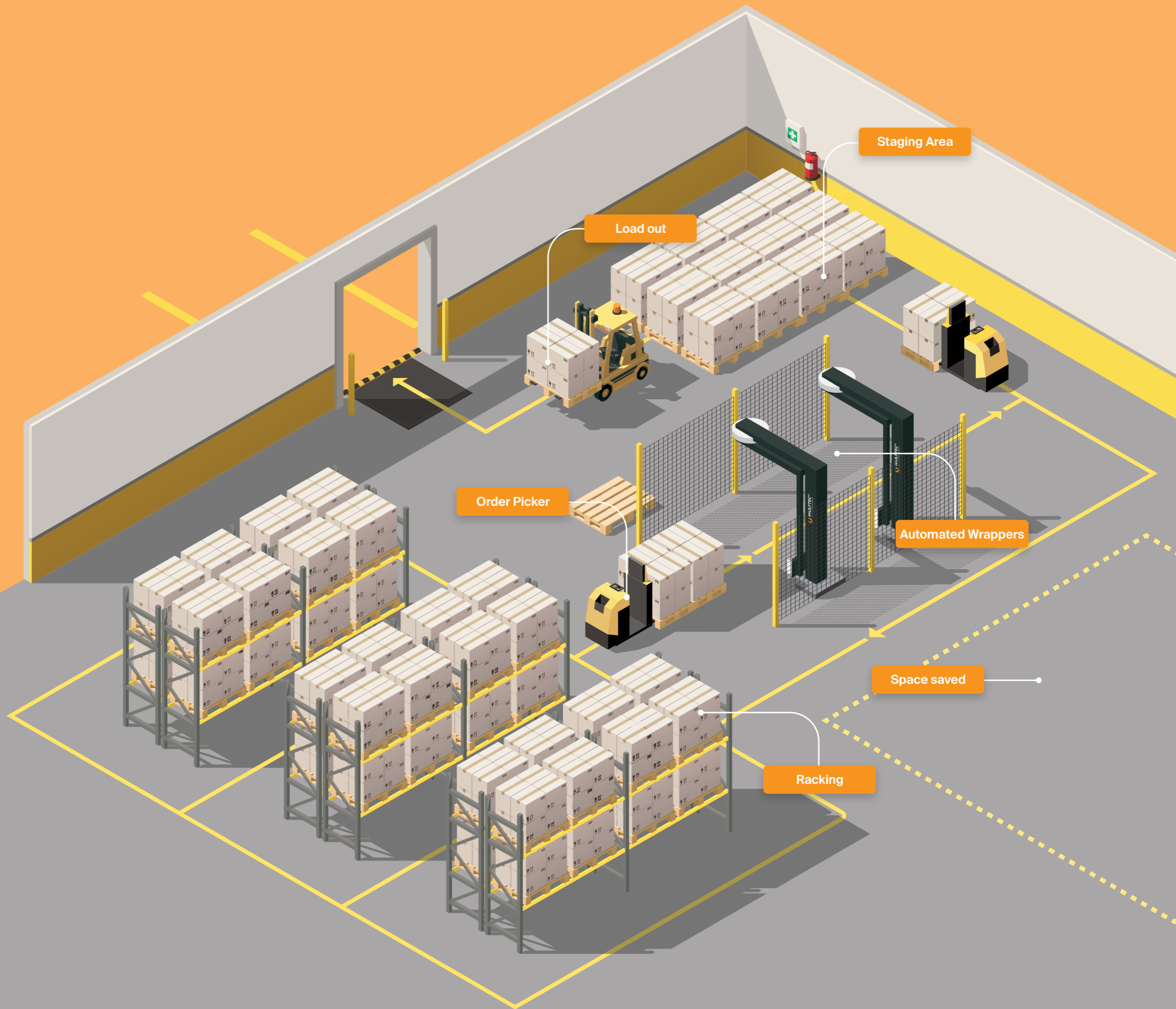

Optimised pick to dispatch

Labour/equipment requirements

1. Picking	 x1	 x1	
2. Wrapped Staging	 x1	 x1	 50-100m ²
3. Dispatch	 x1	 x1	 50-100m ²

Dual Systems

- .1** Angled carriage allows pallet to be wrapped from 5cm above floor level.

- .2** Fully automatic cycle. Cut & wipe ensures there is no need for any human intervention during the cycle.

- .3** Side by side machines allows for operator to drive in and drive out in one movement.

- .4** Rotary arm that can wrap pallets of any weight, shape or conguration.

- .5** Dual system can wrap two pallets at the same time. Order picker can drop pallets immediately after they have been picked.

- .6** Photocell for automatic load height detection.

- .7** Full safety system and light curtain to ensure safe pallets, safe people and safer machinery.





WRTA150

Fully Automated Stretch Wrapper

The WRTA-150 is an automatic rotary arm wrapper with flexibility in functionality, making it ideal for odd shaped loads and allowing for unlimited load weight capacity. As it automatically applies and seals off stretch film there's no waiting around either.



Features

- Quality equipment made in Canada
- 4 year unlimited cycle warranty
- 10 year warranty on structural steel frame
- Lifetime warranty on pre-stretch rollers blue compound
- Fully automated film clamp, welding and film cutting device
- Superior driving mechanism with heavy duty ring gear with pinion gear drive
- Angled carriage to wrap approximately 2% above floor level
- Emergency stop sensor for arm path obstruction
- Soft start and stop rotary arm function
- Photo cell for automatic load height detection
- State-of-the-art electrical Nema 4/12 control panel, dust tight, waterproof, UL508A approved with all finger safe electrical components
- 100% structural steel construction
- Superior electrical/electronic design including Allen Bradley Micrologix PLC and AC drives
- Wulftec's exclusive 500mm nothread® powered pre-stretch carriage (760mm optional)
- Easily available non-proprietary parts
- Dual carriage lifting chains enclosed inside tower for operator safety
- Electronic control panel with four programmable wrapping cycles
- Single phase
- Full service maintenance plans
- Parts backup
- Excellent after sales support and operator training

Specifications

Rotary Arm Speed	0 to 17 rpm
Maximum Load Size	1400mmL x 1400mmW x 2035mmH
Load Weight	Unlimited
Wrap Height	2000mm
Production Rate	50 loads Per hour
Power Supply	Single Phase



Foodtsuffs RLDC Palmerston North



SMH150

Semi Automated Stretch Wrapper

Introducing the Wulftec SMH-150 model – a high quality, high profile turntable wrapper. Also available with an extended turntable specifically designed as the ideal stretch wrapping solution for standard New Zealand dairy board pallets.



Features

- Quality equipment made in Canada
- 5 year unlimited cycle warranty
- 10 year warranty on structural steel frame
- Lifetime warranty on pre-stretch rollers blue compound
- Soft start and stop turntable function
- Indexed turntable returns to start
- Photo cell for automatic load height detection
- State-of-the-art electrical Nema 4/12 control panel, dust tight, waterproof, UL508A approved with all finger safe electrical components
- 100% structural steel construction
- Superior electrical/electronic design including Allen Bradley Micrologix PLC and AC drives
- Wulftec's exclusive 500mm no-thread® powered pre-stretch carriage (760mm optional)
- Easily available non-proprietary parts
- Dual carriage lifting chains enclosed inside tower for operator safety
- Electronic control panel with four programmable wrapping cycles
- Full service maintenance plans
- Parts backup
- Excellent after sales support and operator training

Specifications

Standard Turntable Diameter	1300mm x 1300mm
Option: Custom Dairy Board Pallet Turntable	2200mm x 1160mm
Turntable Speed	0 to 16 rpm
Turntable Height	340mm
Load Weight	1800 kg
Wrap Height	2000 mm
Production Rate Per hour	25 loads
Power Supply	Single Phase



Photo: Open Country Dairy



WCRT200

Fully Automated Stretch Wrapper

This automatic conveyerised wrapper features a heavy-duty ring gear driven rotary arm. Automatically applying and sealing of stretch film, it improves load stability and packaging efficiency.



Features

- Quality equipment made in Canada
- 3 year unlimited cycle warranty
- 10 year warranty on structural steel frame
- Lifetime warranty on pre-stretch rollers blue compound
- Fully automated film clamp, welding and film cutting device
- Fully automated in-feed, process and out-feed roller conveyors
- Superior driving mechanism with heavy duty 25" ring gear with pinion gear drive
- Angled carriage to wrap approximately 2% above conveyor
- Emergency stop sensor for arm path obstruction
- Soft start and stop rotary arm function
- Allen Bradley monochrome touch screen – play an active part in avoiding operator errors by offering a great versatility for customised information and alarm diagnostic
- Photo cell for automatic load height detection
- State-of-the-art electrical Nema 4/12 control panel, dust tight, waterproof, UL508A approved with all finger safe electrical components
- 100% structural steel construction
- Superior electrical/electronic design including Allen Bradley Micrologix PLC and AC drives
- Wulftec's exclusive 500mm no-thread® powered pre-stretch carriage (760mm optional)
- Easily available non-proprietary parts
- Dual carriage lifting chains enclosed inside tower for operator safety
- Electronic control panel with four programmable wrapping cycles
- 3 phase
- Full service maintenance plans
- Parts backup
- Excellent after sales support and operator training wrapping

Specifications

Rotary Arm Speed	0 to 15 rpm
Maximum Load Size	1220mmL x 1220mmW x 2035mmH
Load Weight	2200 kg
Wrap Height	2000mm
Production Rate	100 loads Per hour
Power Supply	3 Phase



Original easy load carriage



Wring250

Fully Automated Stretch Wrapper

This fully conveyerised automatic ring machine is the ideal stretch wrapping solution for your unique needs. Expect to markedly improve productivity and operator efficiency while reducing film and labour costs.



Features

- Quality equipment made in Canada
- 3 year unlimited cycle warranty
- 10 year warranty on structural steel frame
- Lifetime warranty on pre-stretch rollers blue compound
- Fully automated film clamp, welding and film cutting device
- Fully automated in-feed, process and out-feed roller conveyors
- Angled carriage to wrap approximately 2% above conveyor
- Emergency stop sensor for arm path obstruction
- Soft start and stop rotary arm function
- Allen Bradley monochrome touch screen – play an active part in avoiding operator errors by offering a great versatility for customised information and alarm diagnostic
- Photo cell for automatic load height detection
- State-of-the-art electrical Nema 4/12 control panel, dust tight, waterproof, UL508A approved with all finger safe electrical components
- 100% structural steel construction
- Superior electrical/electronic design including Allen Bradley Micrologix PLC and AC drives
- Wulftec's exclusive 500mm no-thread® powered pre-stretch carriage (760mm optional)
- Easily available non-proprietary parts
- Electronic control panel with four programmable wrapping cycles
- 3 phase
- Full service maintenance plans
- Parts backup
- Excellent after sales support and operator training wrapping

Specifications

Ring Speed	0 to 25 rpm
Maximum Load Size	1220mmL x 1020mmW x 2035mmH
Load Weight	2200 kg
Wrap Height	2000mm
Production Rate	75 loads Per hour
Power Supply	3 Phase



Heavy duty roller conveyors

Collective expertise. Cohesive service. United success.

At Universal Packaging we're proud of our commitment to quality service. We know that in the art and science of logistics there can be millions made in the millimetres gained.

Support

The last thing you want to be thinking about is your equipment breaking down. Yet over the lifetime of a stretch wrapper machine things will occasionally go wrong. We've developed our support system over the years to ensure we can deliver expertise when you need it, be it at the end of a phone or on site with the machine.

We didn't get where we are by settling for second best when it comes to quality client service.

We have a trusted network of expert service agents throughout New Zealand. They provide fast repairs, routine maintenance and service checks on pallet wrappers and can quickly respond to emergency call outs for fast assistance. Our stretch-wrap equipment uses a high proportion of non-proprietary components also, allowing us to quickly and easily source parts. So any production downtime is kept to a minimum.

Resources

Staying up to date with industry knowledge is key to optimising and maintaining your distribution capability. We've got the information for your innovation.

We invest in our training videos, tech guides, news articles and white papers to ensure our customers can stay up to speed with everything on offer. This knowledge is regularly sent out via The Binder, our ongoing newsletter, and it's also hosted online.

Training

There are a lot of moving parts within pallet wrapping equipment and many things to know to ensure everything continues to run smoothly.

We can provide your distribution centre training in pallet wrapping either online or in person. This training can be undertaken either with a new equipment purchase or as refresher courses. In this way we can ensure every team member knows how to get the most from your pallet packaging.





Auckland:

1 Lady Fisher Place
East Tamaki, Auckland, 2013

Palmerston North:

Sales & Service Office

Wellington:

480 Jackson Street
Petone, Wellington, 5012

Christchurch:

137 Hayton Road,
Wigram, Christchurch, 8042

To find out more get in touch today at
or on **0800 700 000**
universalpackaging.co.nz